

**Our ref: JBB8663.C7921**

321 Bradford Street  
Birmingham, West Midlands  
B5 6ET  
T +44 121 622 8520

Date: 10 December 2021

To Kelly Harris  
Planning Policy Team  
South Staffordshire District Council

Dear Kelly,

### **South Staffordshire Local Plan Preferred Options (Regulation 18) Consultation November – December 2021**

This letter sets out representations on behalf of IM land, who has an interest in Land at Perton Golf Course (site ref. 705) and are working with landowners. The response seeks to address the omission of the site from the Preferred Options Document, with particular reference to aspects of the evidence base relation to highways.

RPS notes that the Housing Site Selection Topic Paper (HSSTP) assessment of the site concludes that:

*“Highways authority raise initial concerns with site access and impact on surrounding junctions”*

Comments are also made regarding concerns regarding cumulative impacts on junctions to north and south of Perton and walking distance to secondary education.

In response, RPS would like to point the Council to discussions that have been ongoing between the site promoter and the County Highways Authority (Staffordshire County Council) on matters relating to the potential traffic impact of proposals for the Land at Perton Golf Course site and other residential development coming forward in the vicinity. Following those discussions, and based on further transport modelling carried out by DTA, an agreement has been reached between the two parties that the proposed improvements at the A41-Wrottesley Park Road junction would mitigate the additional forecast traffic generated by the proposals. In addition, the transport modelling shows both the golf course access and Wrottesley Park Road/ The Parkway roundabout are demonstrated to operate within capacity in the future with the cumulative development traffic associated with the site and adjacent residential schemes.

A proportional contribution towards the necessary scheme would be provided by the developer. This position has also been agreed with SCC as the Local Highway Authority. Due to the distance of the site from the nearest secondary school the developer would need to provide financial contributions in accordance with the Council's school transport contribution policy.

The full details of the latest modelling work undertaken by DTA, dated 16 November 2021, is appended to this submission (Appendix A).

**Our ref: JBB8663.C7921**

On this basis, there are no transport and highway reasons why the site should not be allocated for residential development. The Council should therefore update its evidence base and site assessment for Land at Perton to account of this latest information.

Yours sincerely,  
for RPS Consulting Services Ltd

A handwritten signature in black ink, appearing to read 'Paul Hill', written in a cursive style.

**Paul Hill MRTPI**  
Senior Planning Director  
RPS Consulting Services Ltd

cc: Sarah Milward, IML

Appendix A

**Land at Perton Golf Course**  
Transport Appraisal



---

### 1.0 INTRODUCTION

- 1.1 This Appraisal has been prepared by DTA Transportation on behalf of IM Land to review the potential traffic impact of proposals to develop 110 residential dwellings at Perton Golf Course. This analysis focusses on the operation of the existing golf club site access, the Wrottesley Park Road/ The Parkway roundabout, and the A41/ Heath House Lane/ Wrottesley Park Road signalised crossroads.
- 1.2 A previous traffic impact note was submitted to Staffordshire County Council (SCC) for consideration and comment. The development assumptions shown below reflect those comments and recommendations received.
- 1.3 Further modelling work was submitted to SCC, and it has been agreed that the proposed development could be accommodated at the Wrottesley Park Road/ A41 junction in combination with those developments presented in section 3 below.
- 1.4 This appraisal has also been updated to address comments in relation to accessibility.



## 2.0 ACCESSIBILITY

2.1 The site is located along the eastern boundary of Perton Golf Course, as indicated on **Figure 1** below.

**Figure 1** - Site Location (Google Maps)

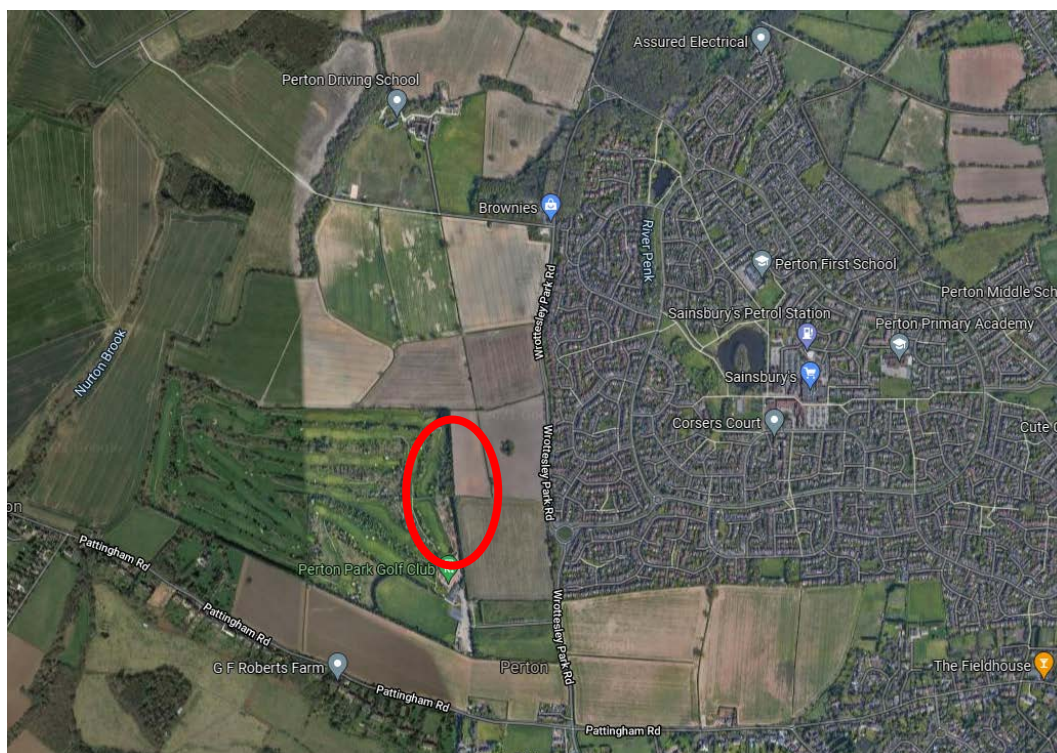

- 2.2 The golf course can currently be accessed by pedestrians via an existing footway along the eastern side of Wrottesley Park Road that connects to the access road.
- 2.3 There is the potential for pedestrian and cycle access to be taken through the adjacent safeguarded land and consented residential development. Which would assist with reducing journey distance.
- 2.4 Due to the good visibility along Wrottesley Park Road and the width of the carriageway, it is considered dropped tactile paving crossing points from the site to the existing footway would be appropriate.
- 2.5 The centre of Perton is approximately 1.6km from the development via the proposed access. To encourage cycling from the site, the developer would be willing to contribute towards improvements to cycle parking facilities in the centre of Perton.



- 
- 2.6 The nearest bus stops are located on The Parkway near to Edgehill Drive. This provides access to the No. 10 service which connects Perton with Codsall and Wolverhampton. Services to between Wolverhampton and Perton are every 20 mins though the day from 06:00 until 23:00 with less frequent services to Codsall.
- 2.7 The No.710 service provides access to Codsall Community High School which is also accessed from The Parkway.
- 2.8 Should the development come forward it is anticipated additional bus stops would be provided near to the site access on Wrottesley Park Road, thereby reducing the walking distance for future residents. In addition, when the development comes forward, if there has been a reduction in bus services and/ or frequency to and from Perton, it is accepted contributions may be required to enhance services.
- 2.9 Due to the distance of the site from the nearest secondary school it is likely that the developer would need to provide financial contributions in accordance with the Council's school transport contribution policy.



### 3.0 DEVELOPMENT ASSUMPTIONS

3.1 To allow for committed and cumulative development within the area, the traffic generated by the following sites has been included in the background flows:

- Site 1 – 220 dwellings on Land to the West of Wrottesley Park Road (consented – planning ref: 18/00436/OUT);
- Site 2 – 210 dwellings on safeguarded land to the north of the consented 220 dwelling scheme; and
- Site 3 – 240 dwellings on land to the north of the safeguarded land, which is being promoted by Richborough Estates.

3.2 The traffic generation for the 210 dwelling and 240 dwellings sites, as well as the proposed development, has been forecast based on the agreed assumptions provided by SCC. The trip rates are set out in **Table 1** with the resultant traffic generation for each site being summarised in **Table 1**.

**Table 1** Locally Derived Trip Rates (per dwelling)

	AM Peak			PM Peak		
	IN	OUT	TOTAL	IN	OUT	TOTAL
Trip Rates	0.080	0.298	0.379	0.305	0.147	0.451

**Table 2** Forecast Vehicle Trip Generation

	AM Peak			PM Peak		
	IN	OUT	TOTAL	IN	OUT	TOTAL
Site 1	18	66	83	67	32	99
Site 2	17	63	80	64	31	95
Site 3	19	72	91	73	35	108
Total Sites 1-3	<b>54</b>	<b>200</b>	<b>254</b>	<b>204</b>	<b>98</b>	<b>302</b>
Golf Course	9	33	42	34	16	50

3.3 The development traffic for all sites have also been assigned based on the agreed assumptions contained within the information provided by SCC. The AM assignment is set out in **Table 3** with the PM being shown in **Table 4** below.



**Table 3** AM Development Assignment

AM Peak	Distribution	Site 1	Site 2	Site 3	Total 1-3	Golf Course
A41 West	7%	6	6	7	18	3
A41 East	35%	29	28	32	90	15
Heath House Lane	15%	12	12	14	38	6
<b>Total North</b>	<b>57%</b>	<b>48</b>	<b>46</b>	<b>52</b>	<b>146</b>	<b>24</b>
Perton Village	8%	7	6	7	20	3
A454 West	7%	6	6	6	18	3
A454 East	28%	23	22	25	70	11
<b>Total South</b>	<b>35%</b>	<b>29</b>	<b>28</b>	<b>31</b>	<b>88</b>	<b>14</b>

**Table 4** PM Development Assignment

PM Peak	Distribution	Site 1	Site 2	Site 3	Total 1-3	Golf Course
A41 West	7%	7	6	7	18	4
A41 East	35%	35	28	32	90	18
Heath House Lane	15%	15	12	14	38	7
<b>Total North</b>	<b>57%</b>	<b>57</b>	<b>46</b>	<b>52</b>	<b>146</b>	<b>28</b>
Perton Village	8%	8	6	7	20	4
A454 West	7%	7	6	6	18	4
A454 East	28%	27	22	25	70	14
<b>Total South</b>	<b>35%</b>	<b>34</b>	<b>28</b>	<b>31</b>	<b>88</b>	<b>17</b>

3.4 As can be seen in the above tables the proposed development at the Golf Course would add little traffic compared to the other three sites. The potential impact of the development at the site access and to the north at the A41 Crossroads has been tested, with the results being set out later in this note.





**4.0 GOLF COURSE ACCESS**

4.1 The operation of the existing golf course access was assessed using the PICADY module in Junctions 9 for the morning and evening peaks. To allow for traffic movements associated with the operation of the golf course, the proposed development flows through the junction were doubled to provide an additional sensitivity test. The assessment flow matrices are attached as **Appendix A**.

4.2 The results of the assessment are summarised in **Table 2** and the full outputs are also attached as **Appendix A**. Overall, the analysis demonstrates that the site access would continue to operate within capacity in the future with the proposed development of 110 dwellings.

**Table 5** Golf Course Access Assessment Results

	AM					PM				
	Set ID	Queue (PCU)	Delay (s)	RFC	LOS	Set ID	Queue (PCU)	Delay (s)	RFC	LOS
<b>2023 + DEV</b>										
Stream B-AC	D1	0.1	10.77	0.10	B	D2	0.1	12.48	0.07	B
Stream C-AB		0.0	3.48	0.03	A		0.1	4.62	0.08	A
<b>2023 + DEV (Sensitivity)</b>										
Stream B-AC	D3	0.3	12.41	0.21	B	D4	0.2	13.92	0.15	B
Stream C-AB		0.1	3.52	0.05	A		0.4	4.84	0.15	A



**5.0 WROTTESLEY PARK ROAD/ THE PARKWAY ROUNDABOUT**

5.1 The operation of the Wroottesley Park Road/ The Parkway roundabout was assessed using the ARCADY module in Junctions 9 for the morning and evening peaks. The assessment flow matrices are attached as **Appendix B**.

5.2 The results of the assessment are summarised in **Table 3** and the full outputs are also attached as **Appendix B**. Overall, the analysis demonstrates that the roundabout would continue to operate within capacity in the future with the proposed development of 110 dwellings.

**Table 6** Wroottesley Park Road/ The Parkway Roundabout Assessment Results

	AM					PM				
	Set ID	Queue (PCU)	Delay (s)	RFC	LOS	Set ID	Queue (PCU)	Delay (s)	RFC	LOS
	<b>2023 + DEV</b>									
Arm A	D1	0.6	2.83	0.36	A	D2	0.2	2.11	0.13	A
Arm B		0.3	2.42	0.23	A		0.8	3.25	0.43	A
Arm C		0.2	5.69	0.18	A		0.1	6.12	0.12	A
Arm D		0.3	2.42	0.20	A		0.4	3.03	0.30	A



**6.0 A41-HEATH HOUSE LANE-WROTTESELEY PARK ROAD SIGNAL JUNCTION**

- 6.1 The operation of the A41/ Heath House Lane/ Wrottesley Park Road signalised crossroads has previously been subject to detailed appraisal by specialised traffic signal consultancy, JCT, to advise SCC on options to improve its operation. This study reported several options including Option B, adjustments to the intergreens between conflicting traffic movements as the existing timings were longer than advised by national guidance, and Option D, physical works to widen approaches to maximise the capacity of the junction.
- 6.2 Following discussions with SCC a refined Option D with a pedestrian crossing was the preferred option.
- 6.3 DTA were provided with a LINSIG model of this junction that reflected the preferred approach. The results were provided to SCC and it was concluded that the proposed layout could accommodate the 3 identified sites as well as the proposed Golf Course Site.
- 6.4 Following discussions with SCC a sensitivity test was requested to ensure that the Golf Course distribution and traffic generation aligned with those used for the other 3 sites.
- 6.5 For ease of reference the “+ development” relates to sites 1 and 2, “Richborough” is site 3, with “All” including the Golf Course Site. The summary results of are below, with output report in **Appendix C**.

**Table 7** A41 Signal Junction

	AM Peak		PM Peak	
	PRC(%)	Delay (pcu/Hr)	PRC(%)	Delay (pcu/Hr)
2032 + Development	-3.0	37.83	19.7	37.73
2032 + Development + Richborough	-5.6	40.64	17.9	39.17
2032 All	-6.5	42.54	17.5	39.80

- 6.6 As can be seen in **Table 7**, the development would have an indiscernible impact on the operation of the proposed signal arrangement, subject to a proportional contribution to the works and supports the conclusions of SCC in that any additional traffic generated by the development can be accommodated at this location.



---

## 7.0 CONCLUSIONS

- 7.1 An assessment has been undertaken of the likely future increases in travel demand arising from development local to Land at Perton Golf Course and the future operation of key local junctions appraised.
- 7.2 The site is within reasonable walking and cycling distance of the centre of Perton, with good access to public transport.
- 7.3 Based on the above analysis, it is concluded that the proposed improvements at the A41-Wrottesley Park Road junction which would mitigate the additional forecast traffic generated by the proposals. A proportional contribution towards the scheme would be provided by the developer. This position has been agreed with SCC as the Local Highway Authority.
- 7.4 Both the golf course access and Wrottesley Park Road/ The Parkway roundabout are demonstrated by the modelling to operate within capacity in the future with the cumulative development traffic associated with the site and adjacent residential schemes.
- 7.5 There are no transport and highway reasons why the site should not be allocated for residential development.

## **Appendix A**

Golf Course Access – PICADY Outputs

Junctions 9
PICADY 9 - Priority Intersection Module
Version: 9.5.1.7462 © Copyright TRL Limited, 2019
For sales and distribution information, program advice and maintenance, contact TRL: +44 (0)1344 379777 software@trl.co.uk www.trlsoftware.co.uk
The users of this computer program for the solution of an engineering problem are in no way relieved of their responsibility for the correctness of the solution

Filename: Golf Club Access.j9  
 Path: P:\21000's\21038\Junction Assessments  
 Report generation date: 13/07/2020 16:01:58

- »2023 + DEV, AM
- »2023 + DEV, PM
- »2023 + DEV (Sensitivity), AM
- »2023 + DEV (Sensitivity), PM

**Summary of junction performance**

	AM					PM				
	Set ID	Queue (PCU)	Delay (s)	RFC	LOS	Set ID	Queue (PCU)	Delay (s)	RFC	LOS
<b>2023 + DEV</b>										
Stream B-AC	D1	0.1	10.77	0.10	B	D2	0.1	12.48	0.07	B
Stream C-AB		0.0	3.48	0.03	A		0.1	4.62	0.08	A
<b>2023 + DEV (Sensitivity)</b>										
Stream B-AC	D3	0.3	12.41	0.21	B	D4	0.2	13.92	0.15	B
Stream C-AB		0.1	3.52	0.05	A		0.4	4.84	0.15	A

*There are warnings associated with one or more model runs - see the 'Data Errors and Warnings' tables for each Analysis or Demand Set.*

*Values shown are the highest values encountered over all time segments. Delay is the maximum value of average delay per arriving vehicle.*

**File summary**

**File Description**

<b>Title</b>	Perton Golf Club
<b>Location</b>	Golf Club Access
<b>Site number</b>	
<b>Date</b>	13/07/2020
<b>Version</b>	
<b>Status</b>	Preliminary
<b>Identifier</b>	
<b>Client</b>	
<b>Jobnumber</b>	
<b>Enumerator</b>	DTA\tommais
<b>Description</b>	

**Units**

Distance units	Speed units	Traffic units input	Traffic units results	Flow units	Average delay units	Total delay units	Rate of delay units
m	kph	PCU	PCU	perHour	s	-Min	perMin

### Analysis Options

Calculate Queue Percentiles	Calculate residual capacity	RFC Threshold	Average Delay threshold (s)	Queue threshold (PCU)
		0.85	36.00	20.00

### Demand Set Summary

ID	Scenario name	Time Period name	Traffic profile type	Start time (HH:mm)	Finish time (HH:mm)	Time segment length (min)
D1	2023 + DEV	AM	ONE HOUR	07:15	08:45	15
D2	2023 + DEV	PM	ONE HOUR	16:45	18:15	15
D3	2023 + DEV (Sensitivity)	AM	ONE HOUR	07:15	08:45	15
D4	2023 + DEV (Sensitivity)	PM	ONE HOUR	16:45	18:15	15

### Analysis Set Details

ID	Network flow scaling factor (%)
A1	100.000

# 2023 + DEV, AM

## Data Errors and Warnings

Severity	Area	Item	Description
Warning	Vehicle Mix		HV% is zero for all movements / time segments. Vehicle Mix matrix should be completed whether working in PCUs or Vehs. If HV% at the junction is genuinely zero, please ignore this warning.

## Junction Network

### Junctions

Junction	Name	Junction type	Major road direction	Use circulating lanes	Junction Delay (s)	Junction LOS
1	untitled	T-Junction	Two-way		0.35	A

### Junction Network Options

Driving side	Lighting
Left	Normal/unknown

## Arms

### Arms

Arm	Name	Description	Arm type
A	Wrottesley Park Road (South)		Major
B	Golf Club Access		Minor
C	Wrottesley Park Road (North)		Major

### Major Arm Geometry

Arm	Width of carriageway (m)	Has kerbed central reserve	Has right turn bay	Visibility for right turn (m)	Blocks?	Blocking queue (PCU)
C	7.70			180.0	✓	0.00

Geometries for Arm C are measured opposite Arm B. Geometries for Arm A (if relevant) are measured opposite Arm D.

### Minor Arm Geometry

Arm	Minor arm type	Lane width (m)	Visibility to left (m)	Visibility to right (m)
B	One lane	2.65	30	30

## Slope / Intercept / Capacity

### Priority Intersection Slopes and Intercepts

Stream	Intercept (PCU/hr)	Slope for A-B	Slope for A-C	Slope for C-A	Slope for C-B
B-A	484	0.082	0.207	0.130	0.295
B-C	620	0.088	0.223	-	-
C-B	678	0.243	0.243	-	-

The slopes and intercepts shown above do NOT include any corrections or adjustments.

Streams may be combined, in which case capacity will be adjusted.

Values are shown for the first time segment only; they may differ for subsequent time segments.



## Traffic Demand

### Demand Set Details

ID	Scenario name	Time Period name	Traffic profile type	Start time (HH:mm)	Finish time (HH:mm)	Time segment length (min)
D1	2023 + DEV	AM	ONE HOUR	07:15	08:45	15

Vehicle mix source	PCU Factor for a HV (PCU)
HV Percentages	2.00

### Demand overview (Traffic)

Arm	Linked arm	Use O-D data	Average Demand (PCU/hr)	Scaling Factor (%)
A		✓	388	100.000
B		✓	35	100.000
C		✓	889	100.000

## Origin-Destination Data

### Demand (PCU/hr)

	To			
	A	B	C	
From	A	0	5	383
	B	15	0	20
	C	883	6	0

## Vehicle Mix

### Heavy Vehicle Percentages

	To			
	A	B	C	
From	A	0	0	0
	B	0	0	0
	C	0	0	0

## Results

### Results Summary for whole modelled period

Stream	Max RFC	Max Delay (s)	Max Queue (PCU)	Max LOS
B-AC	0.10	10.77	0.1	B
C-AB	0.03	3.48	0.0	A
C-A				
A-B				
A-C				

### Main Results for each time segment

#### 07:15 - 07:30

Stream	Total Demand (PCU/hr)	Capacity (PCU/hr)	RFC	Throughput (PCU/hr)	End queue (PCU)	Delay (s)	Unsignalised level of service
B-AC	26	435	0.061	26	0.1	8.804	A
C-AB	12	1048	0.012	12	0.0	3.476	A
C-A	657			657			
A-B	4			4			
A-C	288			288			

#### 07:30 - 07:45

Stream	Total Demand (PCU/hr)	Capacity (PCU/hr)	RFC	Throughput (PCU/hr)	End queue (PCU)	Delay (s)	Unsignalised level of service
B-AC	31	409	0.077	31	0.1	9.518	A
C-AB	18	1125	0.016	18	0.0	3.250	A
C-A	781			781			
A-B	4			4			
A-C	344			344			

#### 07:45 - 08:00

Stream	Total Demand (PCU/hr)	Capacity (PCU/hr)	RFC	Throughput (PCU/hr)	End queue (PCU)	Delay (s)	Unsignalised level of service
B-AC	39	373	0.103	38	0.1	10.763	B
C-AB	31	1236	0.025	31	0.0	2.986	A
C-A	948			948			
A-B	6			6			
A-C	422			422			

#### 08:00 - 08:15

Stream	Total Demand (PCU/hr)	Capacity (PCU/hr)	RFC	Throughput (PCU/hr)	End queue (PCU)	Delay (s)	Unsignalised level of service
B-AC	39	373	0.103	39	0.1	10.767	B
C-AB	31	1236	0.025	31	0.0	2.986	A
C-A	948			948			
A-B	6			6			
A-C	422			422			

#### 08:15 - 08:30

Stream	Total Demand (PCU/hr)	Capacity (PCU/hr)	RFC	Throughput (PCU/hr)	End queue (PCU)	Delay (s)	Unsignalised level of service
B-AC	31	409	0.077	32	0.1	9.531	A
C-AB	18	1126	0.016	18	0.0	3.253	A
C-A	781			781			
A-B	4			4			
A-C	344			344			

#### 08:30 - 08:45

Stream	Total Demand (PCU/hr)	Capacity (PCU/hr)	RFC	Throughput (PCU/hr)	End queue (PCU)	Delay (s)	Unsignalised level of service
B-AC	26	435	0.061	26	0.1	8.818	A
C-AB	12	1048	0.012	12	0.0	3.479	A
C-A	657			657			
A-B	4			4			
A-C	288			288			

# 2023 + DEV, PM

## Data Errors and Warnings

Severity	Area	Item	Description
Warning	Vehicle Mix		HV% is zero for all movements / time segments. Vehicle Mix matrix should be completed whether working in PCUs or Vehs. If HV% at the junction is genuinely zero, please ignore this warning.

## Junction Network

### Junctions

Junction	Name	Junction type	Major road direction	Use circulating lanes	Junction Delay (s)	Junction LOS
1	untitled	T-Junction	Two-way		0.37	A

### Junction Network Options

Driving side	Lighting
Left	Normal/unknown

## Traffic Demand

### Demand Set Details

ID	Scenario name	Time Period name	Traffic profile type	Start time (HH:mm)	Finish time (HH:mm)	Time segment length (min)
D2	2023 + DEV	PM	ONE HOUR	16:45	18:15	15

Vehicle mix source	PCU Factor for a HV (PCU)
HV Percentages	2.00

### Demand overview (Traffic)

Arm	Linked arm	Use O-D data	Average Demand (PCU/hr)	Scaling Factor (%)
A		✓	769	100.000
B		✓	20	100.000
C		✓	543	100.000

## Origin-Destination Data

### Demand (PCU/hr)

		To		
		A	B	C
From	A	0	17	752
	B	9	0	11
	C	521	22	0

## Vehicle Mix

### Heavy Vehicle Percentages

		To		
		A	B	C
From	A	0	0	0
	B	0	0	0
	C	0	0	0

## Results

### Results Summary for whole modelled period

Stream	Max RFC	Max Delay (s)	Max Queue (PCU)	Max LOS
B-AC	0.07	12.48	0.1	B
C-AB	0.08	4.62	0.1	A
C-A				
A-B				
A-C				

### Main Results for each time segment

#### 16:45 - 17:00

Stream	Total Demand (PCU/hr)	Capacity (PCU/hr)	RFC	Throughput (PCU/hr)	End queue (PCU)	Delay (s)	Unsignalised level of service
B-AC	15	390	0.039	15	0.0	9.592	A
C-AB	32	812	0.039	32	0.1	4.610	A
C-A	377			377			
A-B	13			13			
A-C	566			566			

#### 17:00 - 17:15

Stream	Total Demand (PCU/hr)	Capacity (PCU/hr)	RFC	Throughput (PCU/hr)	End queue (PCU)	Delay (s)	Unsignalised level of service
B-AC	18	357	0.050	18	0.1	10.609	B
C-AB	44	846	0.053	44	0.1	4.492	A
C-A	444			444			
A-B	15			15			
A-C	676			676			

#### 17:15 - 17:30

Stream	Total Demand (PCU/hr)	Capacity (PCU/hr)	RFC	Throughput (PCU/hr)	End queue (PCU)	Delay (s)	Unsignalised level of service
B-AC	22	310	0.071	22	0.1	12.473	B
C-AB	68	895	0.076	67	0.1	4.348	A
C-A	530			530			
A-B	19			19			
A-C	828			828			

#### 17:30 - 17:45

Stream	Total Demand (PCU/hr)	Capacity (PCU/hr)	RFC	Throughput (PCU/hr)	End queue (PCU)	Delay (s)	Unsignalised level of service
B-AC	22	310	0.071	22	0.1	12.482	B
C-AB	68	896	0.076	68	0.1	4.350	A
C-A	530			530			
A-B	19			19			
A-C	828			828			

**17:45 - 18:00**

Stream	Total Demand (PCU/hr)	Capacity (PCU/hr)	RFC	Throughput (PCU/hr)	End queue (PCU)	Delay (s)	Unsignalised level of service
B-AC	18	357	0.050	18	0.1	10.620	B
C-AB	45	846	0.053	45	0.1	4.495	A
C-A	444			444			
A-B	15			15			
A-C	676			676			

**18:00 - 18:15**

Stream	Total Demand (PCU/hr)	Capacity (PCU/hr)	RFC	Throughput (PCU/hr)	End queue (PCU)	Delay (s)	Unsignalised level of service
B-AC	15	390	0.039	15	0.0	9.605	A
C-AB	32	813	0.040	32	0.1	4.616	A
C-A	377			377			
A-B	13			13			
A-C	566			566			

# 2023 + DEV (Sensitivity), AM

## Data Errors and Warnings

Severity	Area	Item	Description
Warning	Vehicle Mix		HV% is zero for all movements / time segments. Vehicle Mix matrix should be completed whether working in PCUs or Vehs. If HV% at the junction is genuinely zero, please ignore this warning.

## Junction Network

### Junctions

Junction	Name	Junction type	Major road direction	Use circulating lanes	Junction Delay (s)	Junction LOS
1	untitled	T-Junction	Two-way		0.76	A

### Junction Network Options

Driving side	Lighting
Left	Normal/unknown

## Traffic Demand

### Demand Set Details

ID	Scenario name	Time Period name	Traffic profile type	Start time (HH:mm)	Finish time (HH:mm)	Time segment length (min)
D3	2023 + DEV (Sensitivity)	AM	ONE HOUR	07:15	08:45	15

Vehicle mix source	PCU Factor for a HV (PCU)
HV Percentages	2.00

### Demand overview (Traffic)

Arm	Linked arm	Use O-D data	Average Demand (PCU/hr)	Scaling Factor (%)
A		✓	393	100.000
B		✓	70	100.000
C		✓	895	100.000

## Origin-Destination Data

### Demand (PCU/hr)

		To		
		A	B	C
From	A	0	10	383
	B	31	0	39
	C	883	12	0

## Vehicle Mix

### Heavy Vehicle Percentages

		To		
		A	B	C
From	A	0	0	0
	B	0	0	0
	C	0	0	0

## Results

### Results Summary for whole modelled period

Stream	Max RFC	Max Delay (s)	Max Queue (PCU)	Max LOS
B-AC	0.21	12.41	0.3	B
C-AB	0.05	3.52	0.1	A
C-A				
A-B				
A-C				

### Main Results for each time segment

#### 07:15 - 07:30

Stream	Total Demand (PCU/hr)	Capacity (PCU/hr)	RFC	Throughput (PCU/hr)	End queue (PCU)	Delay (s)	Unsignalised level of service
B-AC	53	430	0.122	52	0.1	9.507	A
C-AB	25	1047	0.024	25	0.0	3.520	A
C-A	649			649			
A-B	8			8			
A-C	288			288			

#### 07:30 - 07:45

Stream	Total Demand (PCU/hr)	Capacity (PCU/hr)	RFC	Throughput (PCU/hr)	End queue (PCU)	Delay (s)	Unsignalised level of service
B-AC	63	404	0.156	63	0.2	10.529	B
C-AB	37	1125	0.033	37	0.0	3.307	A
C-A	768			768			
A-B	9			9			
A-C	344			344			

#### 07:45 - 08:00

Stream	Total Demand (PCU/hr)	Capacity (PCU/hr)	RFC	Throughput (PCU/hr)	End queue (PCU)	Delay (s)	Unsignalised level of service
B-AC	77	367	0.210	77	0.3	12.383	B
C-AB	62	1236	0.050	62	0.1	3.066	A
C-A	923			923			
A-B	11			11			
A-C	422			422			

#### 08:00 - 08:15

Stream	Total Demand (PCU/hr)	Capacity (PCU/hr)	RFC	Throughput (PCU/hr)	End queue (PCU)	Delay (s)	Unsignalised level of service
B-AC	77	367	0.210	77	0.3	12.411	B
C-AB	62	1236	0.050	62	0.1	3.067	A
C-A	923			923			
A-B	11			11			
A-C	422			422			

**08:15 - 08:30**

Stream	Total Demand (PCU/hr)	Capacity (PCU/hr)	RFC	Throughput (PCU/hr)	End queue (PCU)	Delay (s)	Unsignalised level of service
B-AC	63	404	0.156	63	0.2	10.561	B
C-AB	37	1125	0.033	37	0.0	3.311	A
C-A	768			768			
A-B	9			9			
A-C	344			344			

**08:30 - 08:45**

Stream	Total Demand (PCU/hr)	Capacity (PCU/hr)	RFC	Throughput (PCU/hr)	End queue (PCU)	Delay (s)	Unsignalised level of service
B-AC	53	430	0.122	53	0.1	9.545	A
C-AB	25	1047	0.024	25	0.0	3.523	A
C-A	649			649			
A-B	8			8			
A-C	288			288			



# 2023 + DEV (Sensitivity), PM

## Data Errors and Warnings

Severity	Area	Item	Description
Warning	Vehicle Mix		HV% is zero for all movements / time segments. Vehicle Mix matrix should be completed whether working in PCUs or Vehs. If HV% at the junction is genuinely zero, please ignore this warning.

## Junction Network

### Junctions

Junction	Name	Junction type	Major road direction	Use circulating lanes	Junction Delay (s)	Junction LOS
1	untitled	T-Junction	Two-way		0.77	A

### Junction Network Options

Driving side	Lighting
Left	Normal/unknown

## Traffic Demand

### Demand Set Details

ID	Scenario name	Time Period name	Traffic profile type	Start time (HH:mm)	Finish time (HH:mm)	Time segment length (min)
D4	2023 + DEV (Sensitivity)	PM	ONE HOUR	16:45	18:15	15

Vehicle mix source	PCU Factor for a HV (PCU)
HV Percentages	2.00

### Demand overview (Traffic)

Arm	Linked arm	Use O-D data	Average Demand (PCU/hr)	Scaling Factor (%)
A		✓	786	100.000
B		✓	40	100.000
C		✓	565	100.000

## Origin-Destination Data

### Demand (PCU/hr)

		To		
		A	B	C
From	A	0	34	752
	B	18	0	22
	C	521	44	0

## Vehicle Mix

### Heavy Vehicle Percentages

		To		
		A	B	C
From	A	0	0	0
	B	0	0	0
	C	0	0	0

## Results

### Results Summary for whole modelled period

Stream	Max RFC	Max Delay (s)	Max Queue (PCU)	Max LOS
B-AC	0.15	13.92	0.2	B
C-AB	0.15	4.84	0.4	A
C-A				
A-B				
A-C				

### Main Results for each time segment

#### 16:45 - 17:00

Stream	Total Demand (PCU/hr)	Capacity (PCU/hr)	RFC	Throughput (PCU/hr)	End queue (PCU)	Delay (s)	Unsignalised level of service
B-AC	30	385	0.078	30	0.1	10.114	B
C-AB	64	810	0.079	64	0.1	4.822	A
C-A	361			361			
A-B	26			26			
A-C	566			566			

#### 17:00 - 17:15

Stream	Total Demand (PCU/hr)	Capacity (PCU/hr)	RFC	Throughput (PCU/hr)	End queue (PCU)	Delay (s)	Unsignalised level of service
B-AC	36	351	0.102	36	0.1	11.406	B
C-AB	89	843	0.106	89	0.2	4.777	A
C-A	419			419			
A-B	31			31			
A-C	676			676			

#### 17:15 - 17:30

Stream	Total Demand (PCU/hr)	Capacity (PCU/hr)	RFC	Throughput (PCU/hr)	End queue (PCU)	Delay (s)	Unsignalised level of service
B-AC	44	303	0.146	44	0.2	13.895	B
C-AB	136	893	0.153	136	0.4	4.762	A
C-A	486			486			
A-B	37			37			
A-C	828			828			

#### 17:30 - 17:45

Stream	Total Demand (PCU/hr)	Capacity (PCU/hr)	RFC	Throughput (PCU/hr)	End queue (PCU)	Delay (s)	Unsignalised level of service
B-AC	44	303	0.146	44	0.2	13.923	B
C-AB	137	893	0.153	137	0.4	4.773	A
C-A	485			485			
A-B	37			37			
A-C	828			828			

**17:45 - 18:00**

Stream	Total Demand (PCU/hr)	Capacity (PCU/hr)	RFC	Throughput (PCU/hr)	End queue (PCU)	Delay (s)	Unsignalised level of service
B-AC	36	351	0.102	36	0.1	11.436	B
C-AB	90	844	0.106	91	0.2	4.790	A
C-A	418			418			
A-B	31			31			
A-C	676			676			

**18:00 - 18:15**

Stream	Total Demand (PCU/hr)	Capacity (PCU/hr)	RFC	Throughput (PCU/hr)	End queue (PCU)	Delay (s)	Unsignalised level of service
B-AC	30	385	0.078	30	0.1	10.142	B
C-AB	65	810	0.080	65	0.2	4.836	A
C-A	361			361			
A-B	26			26			
A-C	566			566			

## **Appendix B**

Wrottesley Park Road/ The Parkway Roundabout – ARCADY Outputs

<b>Junctions 9</b>
<b>ARCADY 9 - Roundabout Module</b>
Version: 9.5.1.7462 © Copyright TRL Limited, 2019
For sales and distribution information, program advice and maintenance, contact TRL: +44 (0)1344 379777 software@trl.co.uk www.trlsoftware.co.uk
<b>The users of this computer program for the solution of an engineering problem are in no way relieved of their responsibility for the correctness of the solution</b>

Filename: The Parkway Roundabout.j9  
 Path: P:\21000's\21038\Junction Assessments  
 Report generation date: 16/07/2020 17:07:24

- »2023 + DEV, AM
- »2023 + DEV, PM

**Summary of junction performance**

	AM					PM				
	Set ID	Queue (PCU)	Delay (s)	RFC	LOS	Set ID	Queue (PCU)	Delay (s)	RFC	LOS
<b>2023 + DEV</b>										
Arm A	D1	0.6	2.83	0.36	A	D2	0.2	2.11	0.13	A
Arm B		0.3	2.42	0.23	A		0.8	3.25	0.43	A
Arm C		0.2	5.69	0.18	A		0.1	6.12	0.12	A
Arm D		0.3	2.42	0.20	A		0.4	3.03	0.30	A

*There are warnings associated with one or more model runs - see the 'Data Errors and Warnings' tables for each Analysis or Demand Set.*

*Values shown are the highest values encountered over all time segments. Delay is the maximum value of average delay per arriving vehicle.*

**File summary**

**File Description**

<b>Title</b>	Perton Golf Club
<b>Location</b>	The Parkway Roundabout
<b>Site number</b>	
<b>Date</b>	13/07/2020
<b>Version</b>	
<b>Status</b>	Preliminary
<b>Identifier</b>	
<b>Client</b>	
<b>Jobnumber</b>	21038
<b>Enumerator</b>	DTA\tommais
<b>Description</b>	

**Units**

Distance units	Speed units	Traffic units input	Traffic units results	Flow units	Average delay units	Total delay units	Rate of delay units
m	kph	PCU	PCU	perHour	s	-Min	perMin

**Analysis Options**

Calculate Queue Percentiles	Calculate residual capacity	RFC Threshold	Average Delay threshold (s)	Queue threshold (PCU)
		0.85	36.00	20.00

### Demand Set Summary

ID	Scenario name	Time Period name	Traffic profile type	Start time (HH:mm)	Finish time (HH:mm)	Time segment length (min)
D1	2023 + DEV	AM	ONE HOUR	07:15	08:45	15
D2	2023 + DEV	PM	ONE HOUR	16:45	18:15	15

### Analysis Set Details

ID	Network flow scaling factor (%)
A1	100.000

# 2023 + DEV, AM

## Data Errors and Warnings

Severity	Area	Item	Description
Warning	Vehicle Mix		HV% is zero for all movements / time segments. Vehicle Mix matrix should be completed whether working in PCUs or Vehs. If HV% at the junction is genuinely zero, please ignore this warning.

## Junction Network

### Junctions

Junction	Name	Junction type	Use circulating lanes	Arm order	Junction Delay (s)	Junction LOS
1	untitled	Standard Roundabout		A, B, C, D	2.87	A

### Junction Network Options

Driving side	Lighting
Left	Normal/unknown

## Arms

### Arms

Arm	Name	Description
A	The Parkway	
B	Wrottesley Park Road (South)	
C	Severn Homes Site Access	
D	Wrottesley Park Road (North)	

### Roundabout Geometry

Arm	V - Approach road half-width (m)	E - Entry width (m)	I' - Effective flare length (m)	R - Entry radius (m)	D - Inscribed circle diameter (m)	PHI - Conflict (entry) angle (deg)	Exit only
A	3.85	10.10	21.7	80.0	66.9	26.0	
B	3.66	9.00	22.3	40.0	66.9	37.0	
C	3.00	3.75	1.0	20.0	66.9	20.5	
D	3.65	9.00	19.6	25.0	66.9	32.0	

### Slope / Intercept / Capacity

#### Roundabout Slope and Intercept used in model

Arm	Final slope	Final intercept (PCU/hr)
A	0.623	2261
B	0.573	2025
C	0.416	1008
D	0.566	1977

The slope and intercept shown above include any corrections and adjustments.

## Traffic Demand

### Demand Set Details

ID	Scenario name	Time Period name	Traffic profile type	Start time (HH:mm)	Finish time (HH:mm)	Time segment length (min)
D1	2023 + DEV	AM	ONE HOUR	07:15	08:45	15

Vehicle mix source	PCU Factor for a HV (PCU)
HV Percentages	2.00

### Demand overview (Traffic)

Arm	Linked arm	Use O-D data	Average Demand (PCU/hr)	Scaling Factor (%)
A		✓	663	100.000
B		✓	403	100.000
C		✓	127	100.000
D		✓	342	100.000

## Origin-Destination Data

### Demand (PCU/hr)

		To			
		A	B	C	D
From	A	0	533	0	130
	B	120	0	19	264
	C	0	59	0	68
	D	23	298	21	0

## Vehicle Mix

### Heavy Vehicle Percentages

		To			
		A	B	C	D
From	A	0	0	0	0
	B	0	0	0	0
	C	0	0	0	0
	D	0	0	0	0

## Results

### Results Summary for whole modelled period

Arm	Max RFC	Max Delay (s)	Max Queue (PCU)	Max LOS
A	0.36	2.83	0.6	A
B	0.23	2.42	0.3	A
C	0.18	5.69	0.2	A
D	0.20	2.42	0.3	A

### Main Results for each time segment

#### 07:15 - 07:30

Arm	Total Demand (PCU/hr)	Circulating flow (PCU/hr)	Capacity (PCU/hr)	RFC	Throughput (PCU/hr)	End queue (PCU)	Delay (s)	Unsignalised level of service
A	499	284	2084	0.240	498	0.3	2.266	A
B	303	113	1960	0.155	303	0.2	2.170	A
C	96	386	847	0.113	95	0.1	4.782	A
D	257	134	1901	0.135	257	0.2	2.190	A



**07:30 - 07:45**

Arm	Total Demand (PCU/hr)	Circulating flow (PCU/hr)	Capacity (PCU/hr)	RFC	Throughput (PCU/hr)	End queue (PCU)	Delay (s)	Unsignalised level of service
A	596	340	2049	0.291	596	0.4	2.476	A
B	362	136	1948	0.186	362	0.2	2.270	A
C	114	462	816	0.140	114	0.2	5.128	A
D	307	161	1886	0.163	307	0.2	2.280	A

**07:45 - 08:00**

Arm	Total Demand (PCU/hr)	Circulating flow (PCU/hr)	Capacity (PCU/hr)	RFC	Throughput (PCU/hr)	End queue (PCU)	Delay (s)	Unsignalised level of service
A	730	416	2002	0.365	729	0.6	2.828	A
B	444	166	1930	0.230	443	0.3	2.421	A
C	140	566	773	0.181	140	0.2	5.686	A
D	377	197	1865	0.202	376	0.3	2.417	A

**08:00 - 08:15**

Arm	Total Demand (PCU/hr)	Circulating flow (PCU/hr)	Capacity (PCU/hr)	RFC	Throughput (PCU/hr)	End queue (PCU)	Delay (s)	Unsignalised level of service
A	730	416	2001	0.365	730	0.6	2.830	A
B	444	166	1930	0.230	444	0.3	2.421	A
C	140	566	772	0.181	140	0.2	5.689	A
D	377	197	1865	0.202	377	0.3	2.417	A

**08:15 - 08:30**

Arm	Total Demand (PCU/hr)	Circulating flow (PCU/hr)	Capacity (PCU/hr)	RFC	Throughput (PCU/hr)	End queue (PCU)	Delay (s)	Unsignalised level of service
A	596	340	2049	0.291	597	0.4	2.481	A
B	362	136	1948	0.186	363	0.2	2.271	A
C	114	462	816	0.140	114	0.2	5.137	A
D	307	161	1886	0.163	308	0.2	2.281	A

**08:30 - 08:45**

Arm	Total Demand (PCU/hr)	Circulating flow (PCU/hr)	Capacity (PCU/hr)	RFC	Throughput (PCU/hr)	End queue (PCU)	Delay (s)	Unsignalised level of service
A	499	285	2083	0.240	500	0.3	2.273	A
B	303	114	1960	0.155	304	0.2	2.172	A
C	96	387	847	0.113	96	0.1	4.793	A
D	257	135	1901	0.135	258	0.2	2.191	A

# 2023 + DEV, PM

## Data Errors and Warnings

Severity	Area	Item	Description
Warning	Vehicle Mix		HV% is zero for all movements / time segments. Vehicle Mix matrix should be completed whether working in PCUs or Vehs. If HV% at the junction is genuinely zero, please ignore this warning.

## Junction Network

### Junctions

Junction	Name	Junction type	Use circulating lanes	Arm order	Junction Delay (s)	Junction LOS
1	untitled	Standard Roundabout		A, B, C, D	3.14	A

### Junction Network Options

Driving side	Lighting
Left	Normal/unknown

## Traffic Demand

### Demand Set Details

ID	Scenario name	Time Period name	Traffic profile type	Start time (HH:mm)	Finish time (HH:mm)	Time segment length (min)
D2	2023 + DEV	PM	ONE HOUR	16:45	18:15	15

Vehicle mix source	PCU Factor for a HV (PCU)
HV Percentages	2.00

### Demand overview (Traffic)

Arm	Linked arm	Use O-D data	Average Demand (PCU/hr)	Scaling Factor (%)
A		✓	235	100.000
B		✓	763	100.000
C		✓	71	100.000
D		✓	469	100.000

## Origin-Destination Data

### Demand (PCU/hr)

	To				
	A	B	C	D	
From	A	0	187	0	48
	B	406	0	65	292
	C	0	33	0	38
	D	71	323	75	0

## Vehicle Mix

### Heavy Vehicle Percentages

	To				
	A	B	C	D	
From	A	0	0	0	0
	B	0	0	0	0
	C	0	0	0	0
	D	0	0	0	0

## Results

### Results Summary for whole modelled period

Arm	Max RFC	Max Delay (s)	Max Queue (PCU)	Max LOS
A	0.13	2.11	0.2	A
B	0.43	3.25	0.8	A
C	0.12	6.12	0.1	A
D	0.30	3.03	0.4	A

### Main Results for each time segment

#### 16:45 - 17:00

Arm	Total Demand (PCU/hr)	Circulating flow (PCU/hr)	Capacity (PCU/hr)	RFC	Throughput (PCU/hr)	End queue (PCU)	Delay (s)	Unsignalised level of service
A	177	324	2059	0.086	177	0.1	1.911	A
B	574	92	1972	0.291	573	0.4	2.570	A
C	53	560	775	0.069	53	0.1	4.985	A
D	353	329	1790	0.197	352	0.2	2.502	A

#### 17:00 - 17:15

Arm	Total Demand (PCU/hr)	Circulating flow (PCU/hr)	Capacity (PCU/hr)	RFC	Throughput (PCU/hr)	End queue (PCU)	Delay (s)	Unsignalised level of service
A	211	387	2020	0.105	211	0.1	1.990	A
B	686	111	1962	0.350	685	0.5	2.818	A
C	64	670	729	0.088	64	0.1	5.410	A
D	422	394	1754	0.240	421	0.3	2.701	A

#### 17:15 - 17:30

Arm	Total Demand (PCU/hr)	Circulating flow (PCU/hr)	Capacity (PCU/hr)	RFC	Throughput (PCU/hr)	End queue (PCU)	Delay (s)	Unsignalised level of service
A	259	474	1965	0.132	259	0.2	2.109	A
B	840	135	1948	0.431	839	0.8	3.243	A
C	78	821	666	0.117	78	0.1	6.116	A
D	516	483	1704	0.303	516	0.4	3.028	A

#### 17:30 - 17:45

Arm	Total Demand (PCU/hr)	Circulating flow (PCU/hr)	Capacity (PCU/hr)	RFC	Throughput (PCU/hr)	End queue (PCU)	Delay (s)	Unsignalised level of service
A	259	475	1965	0.132	259	0.2	2.109	A
B	840	135	1948	0.431	840	0.8	3.249	A
C	78	821	666	0.117	78	0.1	6.121	A
D	516	483	1703	0.303	516	0.4	3.031	A

**17:45 - 18:00**

Arm	Total Demand (PCU/hr)	Circulating flow (PCU/hr)	Capacity (PCU/hr)	RFC	Throughput (PCU/hr)	End queue (PCU)	Delay (s)	Unsignalised level of service
A	211	388	2019	0.105	211	0.1	1.991	A
B	686	111	1962	0.350	687	0.5	2.826	A
C	64	671	729	0.088	64	0.1	5.419	A
D	422	395	1753	0.240	422	0.3	2.704	A

**18:00 - 18:15**

Arm	Total Demand (PCU/hr)	Circulating flow (PCU/hr)	Capacity (PCU/hr)	RFC	Throughput (PCU/hr)	End queue (PCU)	Delay (s)	Unsignalised level of service
A	177	325	2058	0.086	177	0.1	1.915	A
B	574	93	1972	0.291	575	0.4	2.578	A
C	53	562	774	0.069	54	0.1	4.998	A
D	353	331	1790	0.197	353	0.2	2.506	A

## **Appendix C**

A41/ Heath House Lane/ Wrottesley Park Road – LINSIG Outputs

**User and Project Details**

<b>Project:</b>	<b>21038 Heath House Ln Junction</b>
<b>Title:</b>	<b>Option D Update – Plus IMP Perton Golf Course</b>
<b>Location:</b>	Wrottesley
<b>Client:</b>	IMP
<b>Date Started:</b>	
<b>Date Completed:</b>	
<b>Additional detail:</b>	
<b>File name:</b>	Heath House Ln Option 2 (DTA v2).lsg3x
<b>Author:</b>	Richard McCulloch
<b>Company:</b>	DTA Transportation
<b>Address:</b>	Forester House, Doctors Lane, Henley in Arden

**Network Layout Diagram**

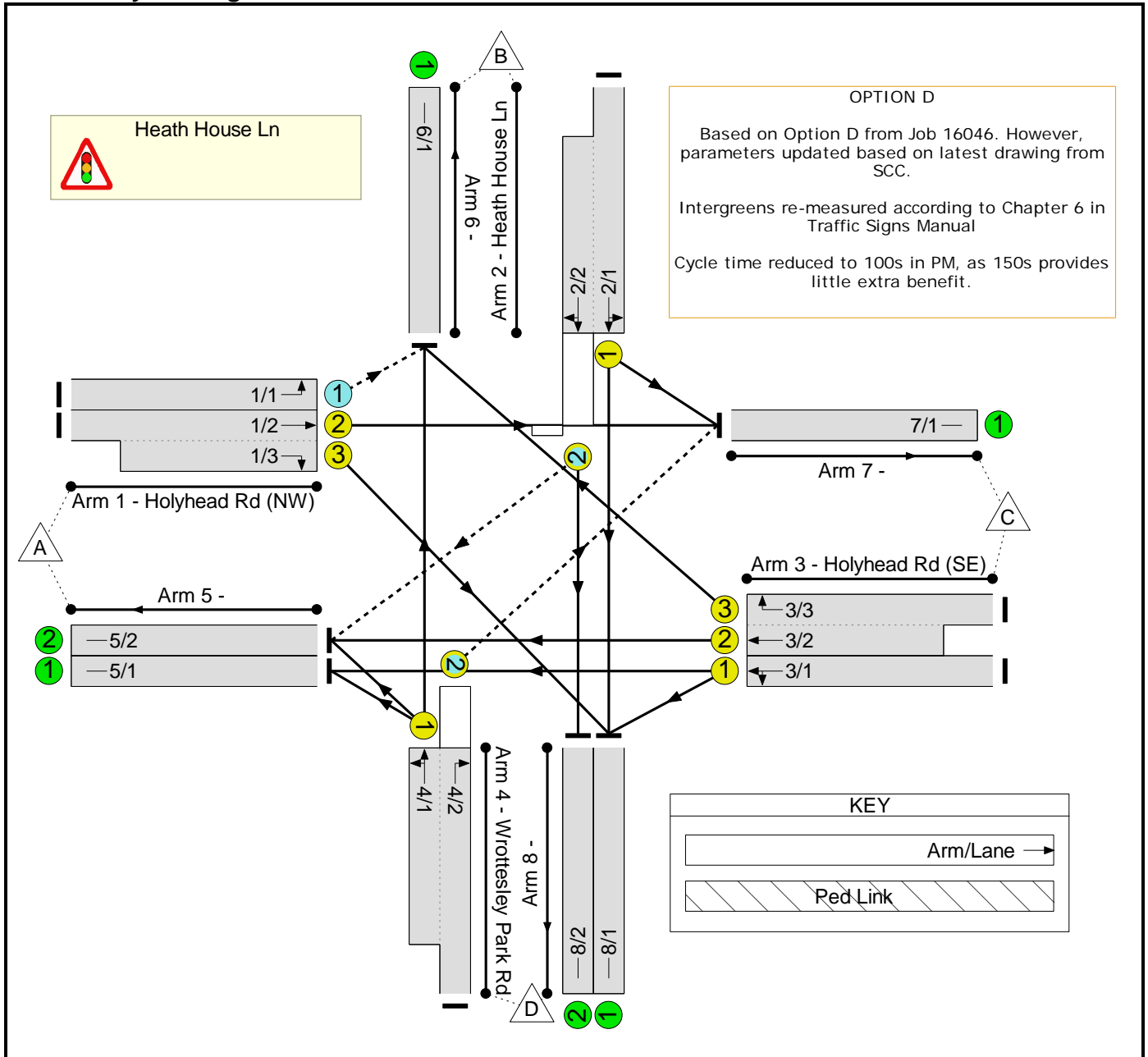

**Phase Diagram**

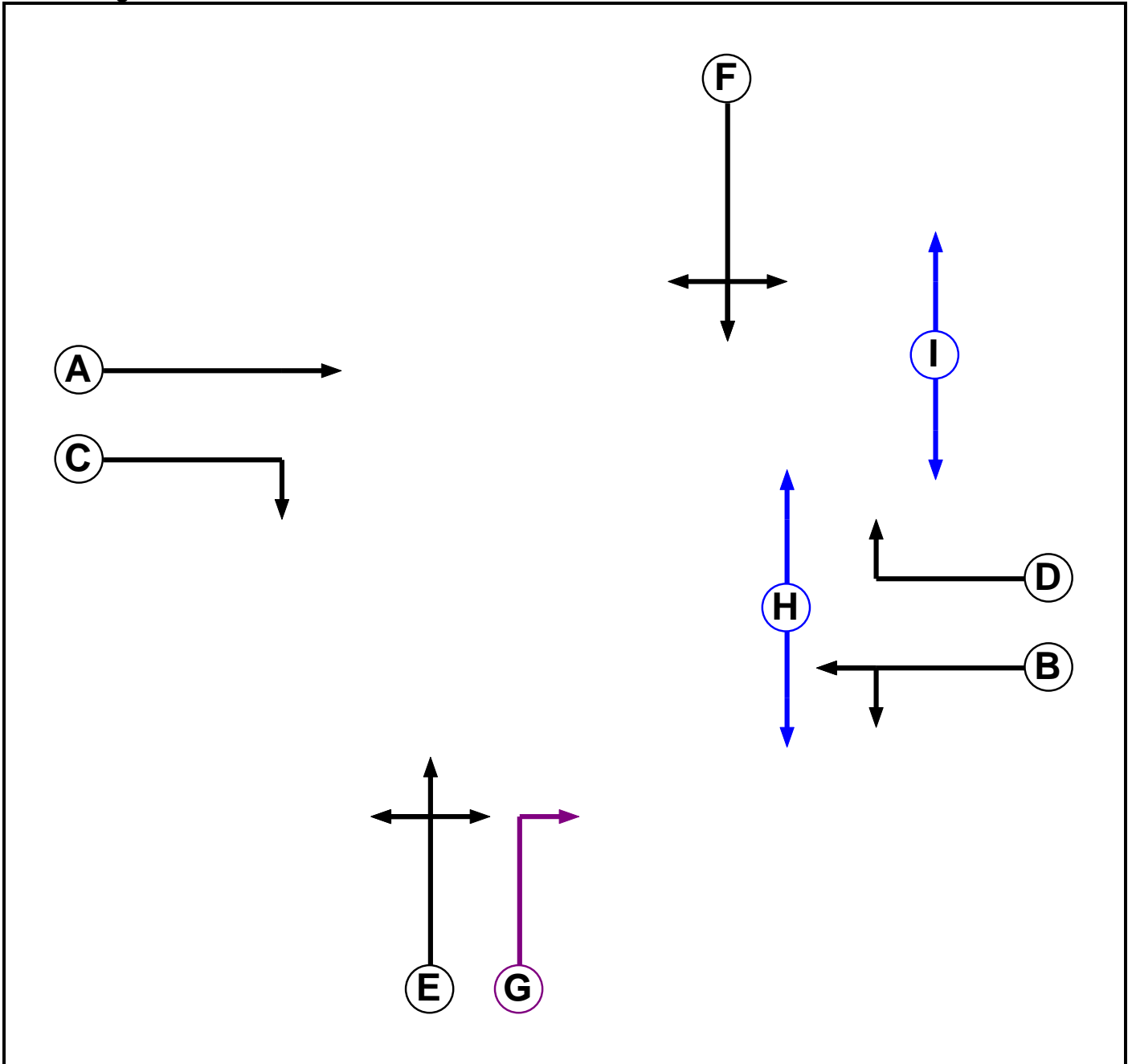

**Phase Input Data**

Phase Name	Phase Type	Assoc. Phase	Street Min	Cont Min
A	Traffic		7	7
B	Traffic		7	7
C	Traffic		7	7
D	Traffic		7	7
E	Traffic		7	7
F	Traffic		7	7
G	Ind. Arrow	E	4	4
H	Pedestrian		6	6
I	Pedestrian		5	3



**Phase Intergreens Matrix**

Terminating Phase	Starting Phase								
	A	B	C	D	E	F	G	H	I
A	-	-	5	5	5	5	-	10	
B	-	7	-	7	5	7	5	-	
C	-	7	-	5	5	5	-	-	
D	8	-	-	6	6	6	5	-	
E	7	5	5	5	-	-	-	10	
F	7	9	7	5	-	3	-	12	
G	5	5	5	5	-	5	-	10	
H	-	12	-	12	-	-	-	-	
I	6	-	-	6	6	6	-	-	

**Phases in Stage**

Stage No.	Phases in Stage
1	B D I
2	A B
3	A C H
4	E F H
5	E G H

**Stage Diagram**

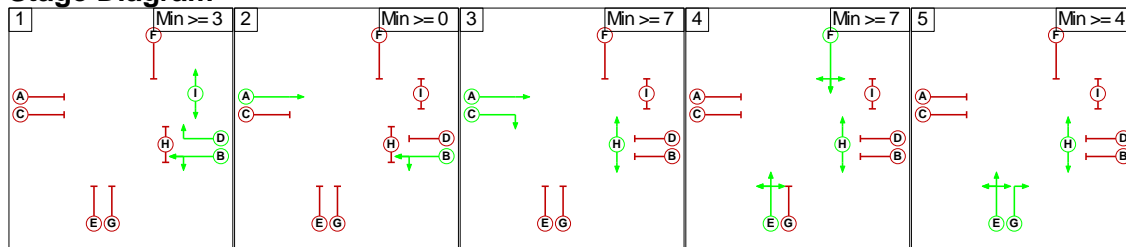

**Phase Delays**

Term. Stage	Start Stage	Phase	Type	Value	Cont value
1	2	I	Losing	2	2
1	3	B	Losing	1	1
1	3	I	Losing	2	2
1	4	B	Losing	1	1
1	4	D	Losing	2	2
1	4	I	Losing	2	2
1	5	B	Losing	1	1
1	5	D	Losing	2	2
1	5	I	Losing	2	2
2	4	A	Losing	2	2
2	5	A	Losing	2	2
3	1	A	Losing	5	5
3	1	C	Losing	5	5
3	2	C	Losing	5	5
4	1	E	Losing	2	2
4	2	E	Losing	5	5
4	2	F	Losing	3	3
5	1	E	Losing	7	7
5	2	E	Losing	5	5
5	3	C	Gaining absolute	7	5

**Prohibited Stage Change**

		To Stage				
		1	2	3	4	5
From Stage	1	8	8	8	8	8
	2	10	7	7	7	7
	3	15	12	5	5	5
	4	12	12	7	3	3
	5	17	12	7	5	5

**Give-Way Lane Input Data**

Junction: Heath House Ln											
Lane	Movement	Max Flow when Giving Way (PCU/Hr)	Min Flow when Giving Way (PCU/Hr)	Opposing Lane	Opp. Lane Coeff.	Opp. Mvmnts.	Right Turn Storage (PCU)	Non-Blocking Storage (PCU)	RTF	Right Turn Move up (s)	Max Turns in Intergreen (PCU)
1/1 (Holyhead Rd (NW))	6/1 (Left)	715	0	3/3	0.22	All	-	-	-	-	-
				4/1	0.22	To 6/1 (Ahead)					
2/2 (Heath House Ln)	5/2 (Right)	1439	0	4/1	1.09	All	5.00	0.50	0.50	5	5.00
4/2 (Wrottesley Park Rd)	7/1 (Right)	1439	0	2/1	1.09	All	3.00	-	0.50	3	3.00
				2/2	1.09	To 8/2 (Ahead)					

**Lane Input Data**

Junction: Heath House Ln												
Lane	Lane Type	Phases	Start Disp.	End Disp.	Physical Length (PCU)	Sat Flow Type	Def User Saturation Flow (PCU/Hr)	Lane Width (m)	Gradient	Nearside Lane	Turns	Turning Radius (m)
1/1 (Holyhead Rd (NW))	O		2	3	60.0	Inf	-	-	-	-	-	-
1/2 (Holyhead Rd (NW))	U	A	2	3	60.0	Geom	-	3.50	0.00	Y	Arm 7 Ahead	Inf
1/3 (Holyhead Rd (NW))	U	C	2	3	15.0	Geom	-	3.50	0.00	Y	Arm 8 Right	43.00
2/1 (Heath House Ln)	U	F	2	3	60.0	Geom	-	3.50	0.00	Y	Arm 7 Left	25.00
											Arm 8 Ahead	Inf
2/2 (Heath House Ln)	O	F	2	3	11.0	Geom	-	3.50	0.00	Y	Arm 5 Right	10.00
											Arm 8 Ahead	Inf
3/1 (Holyhead Rd (SE))	U	B	2	3	60.0	Geom	-	3.50	0.00	Y	Arm 5 Ahead	Inf
3/2 (Holyhead Rd (SE))	U	B	2	3	10.0	Geom	-	3.50	0.00	N	Arm 8 Left	14.00
3/3 (Holyhead Rd (SE))	U	D	2	3	60.0	Geom	-	3.50	0.00	Y	Arm 5 Ahead	Inf
4/1 (Wrottesley Park Rd)	U	E	2	3	20.0	Geom	-	3.00	0.00	Y	Arm 6 Right	32.00
											Arm 5 Left	21.00
4/2 (Wrottesley Park Rd)	U	E G	2	3	60.0	Geom	-	3.00	0.00	Y	Arm 6 Ahead	Inf
4/2 (Wrottesley Park Rd)	O	E G	2	3	60.0	Geom	-	3.00	0.00	Y	Arm 7 Right	10.00
5/1	U		2	3	60.0	Inf	-	-	-	-	-	-
5/2	U		2	3	60.0	Inf	-	-	-	-	-	-
6/1	U		2	3	60.0	Inf	-	-	-	-	-	-
7/1	U		2	3	60.0	Inf	-	-	-	-	-	-
8/1	U		2	3	60.0	Inf	-	-	-	-	-	-
8/2	U		2	3	60.0	Inf	-	-	-	-	-	-

**Traffic Flow Groups**

Flow Group	Start Time	End Time	Duration	Formula
1: 'AM 2032'	07:30	08:30	01:00	
2: 'AM 2032 + Development'	07:30	08:30	01:00	F1+F7
3: 'AM 2032 + Development + Richborough'	07:30	08:30	01:00	F1+F7+F8
4: 'PM 2032'	17:00	18:00	01:00	
5: 'PM 2032 + Development'	17:00	18:00	01:00	F4+F9
6: 'PM 2032 + Development + Richborough'	17:00	18:00	01:00	F4+F9+F10
13: 'AM 2032 (All)'	07:30	08:30	01:00	F3+F11
14: 'PM 2032 (All)'	17:00	18:00	01:00	F6+F12

**Scenario 1: 'AM32+Dev'** (FG2: 'AM 2032 + Development', Plan 1: '12345')

**Traffic Flows, Desired**

**Desired Flow :**

		Destination				
		A	B	C	D	Tot.
Origin	A	0	15	532	97	644
	B	41	0	33	313	387
	C	571	25	0	91	687
	D	230	572	179	0	981
	Tot.	842	612	744	501	2699

**Traffic Lane Flows**

Lane	Scenario 1: AM32+Dev
<b>Junction: Heath House Ln</b>	
1/1	15
1/2 (with short)	629(In) 532(Out)
1/3 (short)	97
2/1 (with short)	387(In) 196(Out)
2/2 (short)	191
3/1	308
3/2 (short)	354
3/3 (with short)	379(In) 25(Out)
4/1 (short)	802
4/2 (with short)	981(In) 179(Out)
5/1	332
5/2	510
6/1	612
7/1	744
8/1	351
8/2	150

**Lane Saturation Flows**

Junction: Heath House Ln								
Lane	Lane Width (m)	Gradient	Nearside Lane	Allowed Turns	Turning Radius (m)	Turning Prop.	Sat Flow (PCU/Hr)	Flared Sat Flow (PCU/Hr)
1/1 (Holyhead Rd (NW) Lane 1)	Infinite Saturation Flow						Inf	Inf
1/2 (Holyhead Rd (NW))	3.50	0.00	Y	Arm 7 Ahead	Inf	100.0 %	1965	1965
1/3 (Holyhead Rd (NW))	3.50	0.00	Y	Arm 8 Right	43.00	100.0 %	1899	1899
2/1 (Heath House Ln)	3.50	0.00	Y	Arm 7 Left	25.00	16.8 %	1945	1945
				Arm 8 Ahead	Inf	83.2 %		
2/2 (Heath House Ln)	3.50	0.00	Y	Arm 5 Right	10.00	21.5 %		
				Arm 8 Ahead	Inf	78.5 %	1904	1904
3/1 (Holyhead Rd (SE))	3.50	0.00	Y	Arm 5 Ahead	Inf	70.5 %	1905	1905
				Arm 8 Left	14.00	29.5 %		
3/2 (Holyhead Rd (SE))	3.50	0.00	N	Arm 5 Ahead	Inf	100.0 %	2105	2105
3/3 (Holyhead Rd (SE))	3.50	0.00	Y	Arm 6 Right	32.00	100.0 %	1877	1877
4/1 (Wrottesley Park Rd)	3.00	0.00	Y	Arm 5 Left	21.00	28.7 %	1877	1877
				Arm 6 Ahead	Inf	71.3 %		
4/2 (Wrottesley Park Rd)	3.00	0.00	Y	Arm 7 Right	10.00	100.0 %	1665	1665
5/1	Infinite Saturation Flow						Inf	Inf
5/2	Infinite Saturation Flow						Inf	Inf
6/1	Infinite Saturation Flow						Inf	Inf
7/1	Infinite Saturation Flow						Inf	Inf
8/1	Infinite Saturation Flow						Inf	Inf
8/2	Infinite Saturation Flow						Inf	Inf

**Scenario 2: 'AM32+Dev+Rich'** (FG3: 'AM 2032 + Development + Richborough', Plan 1: '12345')

**Traffic Flows, Desired**

**Desired Flow :**

	Destination					
	A	B	C	D	Tot.	
Origin	A	0	15	532	98	645
	B	41	0	33	320	394
	C	571	25	0	94	690
	D	235	597	190	0	1022
	Tot.	847	637	755	512	2751

**Traffic Lane Flows**

Lane	Scenario 2: AM32+Dev+Rich
<b>Junction: Heath House Ln</b>	
1/1	15
1/2 (with short)	630(In) 532(Out)
1/3 (short)	98
2/1 (with short)	394(In) 199(Out)
2/2 (short)	195
3/1	309
3/2 (short)	356
3/3 (with short)	381(In) 25(Out)
4/1 (short)	832
4/2 (with short)	1022(In) 190(Out)
5/1	333
5/2	514
6/1	637
7/1	755
8/1	358
8/2	154



**Lane Saturation Flows**

Junction: Heath House Ln								
Lane	Lane Width (m)	Gradient	Nearside Lane	Allowed Turns	Turning Radius (m)	Turning Prop.	Sat Flow (PCU/Hr)	Flared Sat Flow (PCU/Hr)
1/1 (Holyhead Rd (NW) Lane 1)	Infinite Saturation Flow						Inf	Inf
1/2 (Holyhead Rd (NW))	3.50	0.00	Y	Arm 7 Ahead	Inf	100.0 %	1965	1965
1/3 (Holyhead Rd (NW))	3.50	0.00	Y	Arm 8 Right	43.00	100.0 %	1899	1899
2/1 (Heath House Ln)	3.50	0.00	Y	Arm 7 Left	25.00	16.6 %	1946	1946
				Arm 8 Ahead	Inf	83.4 %		
2/2 (Heath House Ln)	3.50	0.00	Y	Arm 5 Right	10.00	21.0 %		
				Arm 8 Ahead	Inf	79.0 %	1905	1905
3/1 (Holyhead Rd (SE))	3.50	0.00	Y	Arm 5 Ahead	Inf	69.6 %	1903	1903
				Arm 8 Left	14.00	30.4 %		
3/2 (Holyhead Rd (SE))	3.50	0.00	N	Arm 5 Ahead	Inf	100.0 %	2105	2105
3/3 (Holyhead Rd (SE))	3.50	0.00	Y	Arm 6 Right	32.00	100.0 %	1877	1877
4/1 (Wrottesley Park Rd)	3.00	0.00	Y	Arm 5 Left	21.00	28.2 %	1877	1877
				Arm 6 Ahead	Inf	71.8 %		
4/2 (Wrottesley Park Rd)	3.00	0.00	Y	Arm 7 Right	10.00	100.0 %	1665	1665
5/1	Infinite Saturation Flow						Inf	Inf
5/2	Infinite Saturation Flow						Inf	Inf
6/1	Infinite Saturation Flow						Inf	Inf
7/1	Infinite Saturation Flow						Inf	Inf
8/1	Infinite Saturation Flow						Inf	Inf
8/2	Infinite Saturation Flow						Inf	Inf

**Scenario 3: 'AM32+LP+Rich+IM'** (FG13: 'AM 2032 (All)', Plan 1: '12345')

**Traffic Flows, Desired**

**Desired Flow :**

	Destination					
	A	B	C	D	Tot.	
Origin	A	0	15	532	99	646
	B	41	0	33	321	395
	C	571	25	0	97	693
	D	237	602	202	0	1041
	Tot.	849	642	767	517	2775

**Traffic Lane Flows**

Lane	Scenario 3: AM32+LP+Rich+IM
<b>Junction: Heath House Ln</b>	
1/1	15
1/2 (with short)	631(In) 532(Out)
1/3 (short)	99
2/1 (with short)	395(In) 199(Out)
2/2 (short)	196
3/1	311
3/2 (short)	357
3/3 (with short)	382(In) 25(Out)
4/1 (short)	839
4/2 (with short)	1041(In) 202(Out)
5/1	333
5/2	516
6/1	642
7/1	767
8/1	362
8/2	155

**Lane Saturation Flows**

Junction: Heath House Ln								
Lane	Lane Width (m)	Gradient	Nearside Lane	Allowed Turns	Turning Radius (m)	Turning Prop.	Sat Flow (PCU/Hr)	Flared Sat Flow (PCU/Hr)
1/1 (Holyhead Rd (NW) Lane 1)	Infinite Saturation Flow						Inf	Inf
1/2 (Holyhead Rd (NW))	3.50	0.00	Y	Arm 7 Ahead	Inf	100.0 %	1965	1965
1/3 (Holyhead Rd (NW))	3.50	0.00	Y	Arm 8 Right	43.00	100.0 %	1899	1899
2/1 (Heath House Ln)	3.50	0.00	Y	Arm 7 Left	25.00	16.6 %	1946	1946
				Arm 8 Ahead	Inf	83.4 %		
2/2 (Heath House Ln)	3.50	0.00	Y	Arm 5 Right	10.00	20.9 %		
				Arm 8 Ahead	Inf	79.1 %	1905	1905
3/1 (Holyhead Rd (SE))	3.50	0.00	Y	Arm 5 Ahead	Inf	68.8 %	1901	1901
				Arm 8 Left	14.00	31.2 %		
3/2 (Holyhead Rd (SE))	3.50	0.00	N	Arm 5 Ahead	Inf	100.0 %	2105	2105
3/3 (Holyhead Rd (SE))	3.50	0.00	Y	Arm 6 Right	32.00	100.0 %	1877	1877
4/1 (Wrottesley Park Rd)	3.00	0.00	Y	Arm 5 Left	21.00	28.2 %	1877	1877
				Arm 6 Ahead	Inf	71.8 %		
4/2 (Wrottesley Park Rd)	3.00	0.00	Y	Arm 7 Right	10.00	100.0 %	1665	1665
5/1	Infinite Saturation Flow						Inf	Inf
5/2	Infinite Saturation Flow						Inf	Inf
6/1	Infinite Saturation Flow						Inf	Inf
7/1	Infinite Saturation Flow						Inf	Inf
8/1	Infinite Saturation Flow						Inf	Inf
8/2	Infinite Saturation Flow						Inf	Inf

**Scenario 4: 'PM32+Dev' (FG5: 'PM 2032 + Development', Plan 1: '12345')**

**Traffic Flows, Desired**

**Desired Flow :**

	Destination					
	A	B	C	D	Tot.	
Origin	A	0	17	580	243	840
	B	18	0	23	542	583
	C	446	41	0	293	780
	D	114	326	170	0	610
	Tot.	578	384	773	1078	2813

**Traffic Lane Flows**

Lane	Scenario 4: PM32+Dev
<b>Junction: Heath House Ln</b>	
1/1	17
1/2 (with short)	823(In) 580(Out)
1/3 (short)	243
2/1 (with short)	583(In) 292(Out)
2/2 (short)	291
3/1	342
3/2 (short)	397
3/3 (with short)	438(In) 41(Out)
4/1 (short)	440
4/2 (with short)	610(In) 170(Out)
5/1	106
5/2	472
6/1	384
7/1	773
8/1	805
8/2	273

**Lane Saturation Flows**

Junction: Heath House Ln								
Lane	Lane Width (m)	Gradient	Nearside Lane	Allowed Turns	Turning Radius (m)	Turning Prop.	Sat Flow (PCU/Hr)	Flared Sat Flow (PCU/Hr)
1/1 (Holyhead Rd (NW) Lane 1)	Infinite Saturation Flow						Inf	Inf
1/2 (Holyhead Rd (NW))	3.50	0.00	Y	Arm 7 Ahead	Inf	100.0 %	1965	1965
1/3 (Holyhead Rd (NW))	3.50	0.00	Y	Arm 8 Right	43.00	100.0 %	1899	1899
2/1 (Heath House Ln)	3.50	0.00	Y	Arm 7 Left	25.00	7.9 %	1956	1956
				Arm 8 Ahead	Inf	92.1 %		
2/2 (Heath House Ln)	3.50	0.00	Y	Arm 5 Right	10.00	6.2 %	1947	1947
				Arm 8 Ahead	Inf	93.8 %		
3/1 (Holyhead Rd (SE))	3.50	0.00	Y	Arm 5 Ahead	Inf	14.3 %	1800	1800
				Arm 8 Left	14.00	85.7 %		
3/2 (Holyhead Rd (SE))	3.50	0.00	N	Arm 5 Ahead	Inf	100.0 %	2105	2105
3/3 (Holyhead Rd (SE))	3.50	0.00	Y	Arm 6 Right	32.00	100.0 %	1877	1877
4/1 (Wrottesley Park Rd)	3.00	0.00	Y	Arm 5 Left	21.00	25.9 %	1880	1880
				Arm 6 Ahead	Inf	74.1 %		
4/2 (Wrottesley Park Rd)	3.00	0.00	Y	Arm 7 Right	10.00	100.0 %	1665	1665
5/1	Infinite Saturation Flow						Inf	Inf
5/2	Infinite Saturation Flow						Inf	Inf
6/1	Infinite Saturation Flow						Inf	Inf
7/1	Infinite Saturation Flow						Inf	Inf
8/1	Infinite Saturation Flow						Inf	Inf
8/2	Infinite Saturation Flow						Inf	Inf

**Scenario 5: 'PM32+Dev+Rich'** (FG6: 'PM 2032 + Development + Richborough', Plan 1: '12345')

**Traffic Flows, Desired**

**Desired Flow :**

	Destination					
	A	B	C	D	Tot.	
Origin	A	0	17	580	248	845
	B	18	0	23	568	609
	C	446	41	0	304	791
	D	117	338	175	0	630
	Tot.	581	396	778	1120	2875

**Traffic Lane Flows**

Lane	Scenario 5: PM32+Dev+Rich
<b>Junction: Heath House Ln</b>	
1/1	17
1/2 (with short)	828(In) 580(Out)
1/3 (short)	248
2/1 (with short)	609(In) 305(Out)
2/2 (short)	304
3/1	347
3/2 (short)	403
3/3 (with short)	444(In) 41(Out)
4/1 (short)	455
4/2 (with short)	630(In) 175(Out)
5/1	102
5/2	479
6/1	396
7/1	778
8/1	834
8/2	286

**Lane Saturation Flows**

Junction: Heath House Ln								
Lane	Lane Width (m)	Gradient	Nearside Lane	Allowed Turns	Turning Radius (m)	Turning Prop.	Sat Flow (PCU/Hr)	Flared Sat Flow (PCU/Hr)
1/1 (Holyhead Rd (NW) Lane 1)	Infinite Saturation Flow						Inf	Inf
1/2 (Holyhead Rd (NW))	3.50	0.00	Y	Arm 7 Ahead	Inf	100.0 %	1965	1965
1/3 (Holyhead Rd (NW))	3.50	0.00	Y	Arm 8 Right	43.00	100.0 %	1899	1899
2/1 (Heath House Ln)	3.50	0.00	Y	Arm 7 Left	25.00	7.5 %	1956	1956
				Arm 8 Ahead	Inf	92.5 %		
2/2 (Heath House Ln)	3.50	0.00	Y	Arm 5 Right	10.00	5.9 %		
				Arm 8 Ahead	Inf	94.1 %	1948	1948
3/1 (Holyhead Rd (SE))	3.50	0.00	Y	Arm 5 Ahead	Inf	12.4 %	1796	1796
				Arm 8 Left	14.00	87.6 %		
3/2 (Holyhead Rd (SE))	3.50	0.00	N	Arm 5 Ahead	Inf	100.0 %	2105	2105
3/3 (Holyhead Rd (SE))	3.50	0.00	Y	Arm 6 Right	32.00	100.0 %	1877	1877
4/1 (Wrottesley Park Rd)	3.00	0.00	Y	Arm 5 Left	21.00	25.7 %	1880	1880
				Arm 6 Ahead	Inf	74.3 %		
4/2 (Wrottesley Park Rd)	3.00	0.00	Y	Arm 7 Right	10.00	100.0 %	1665	1665
5/1	Infinite Saturation Flow						Inf	Inf
5/2	Infinite Saturation Flow						Inf	Inf
6/1	Infinite Saturation Flow						Inf	Inf
7/1	Infinite Saturation Flow						Inf	Inf
8/1	Infinite Saturation Flow						Inf	Inf
8/2	Infinite Saturation Flow						Inf	Inf

**Scenario 6: 'PM32+LP+Rich+IM' (FG14: 'PM 2032 (All)', Plan 1: '12345')**

**Traffic Flows, Desired**

**Desired Flow :**

	Destination					
	A	B	C	D	Tot.	
Origin	A	0	17	580	250	847
	B	18	0	23	573	614
	C	446	41	0	316	803
	D	118	340	181	0	639
	Tot.	582	398	784	1139	2903

**Traffic Lane Flows**

Lane	Scenario 6: PM32+LP+Rich+IM
<b>Junction: Heath House Ln</b>	
1/1	17
1/2 (with short)	830(In) 580(Out)
1/3 (short)	250
2/1 (with short)	614(In) 308(Out)
2/2 (short)	306
3/1	353
3/2 (short)	409
3/3 (with short)	450(In) 41(Out)
4/1 (short)	458
4/2 (with short)	639(In) 181(Out)
5/1	96
5/2	486
6/1	398
7/1	784
8/1	851
8/2	288



**Lane Saturation Flows**

Junction: Heath House Ln								
Lane	Lane Width (m)	Gradient	Nearside Lane	Allowed Turns	Turning Radius (m)	Turning Prop.	Sat Flow (PCU/Hr)	Flared Sat Flow (PCU/Hr)
1/1 (Holyhead Rd (NW) Lane 1)	Infinite Saturation Flow						Inf	Inf
1/2 (Holyhead Rd (NW))	3.50	0.00	Y	Arm 7 Ahead	Inf	100.0 %	1965	1965
1/3 (Holyhead Rd (NW))	3.50	0.00	Y	Arm 8 Right	43.00	100.0 %	1899	1899
2/1 (Heath House Ln)	3.50	0.00	Y	Arm 7 Left	25.00	7.5 %	1956	1956
				Arm 8 Ahead	Inf	92.5 %		
2/2 (Heath House Ln)	3.50	0.00	Y	Arm 5 Right	10.00	5.9 %	1948	1948
				Arm 8 Ahead	Inf	94.1 %		
3/1 (Holyhead Rd (SE))	3.50	0.00	Y	Arm 5 Ahead	Inf	10.5 %	1793	1793
				Arm 8 Left	14.00	89.5 %		
3/2 (Holyhead Rd (SE))	3.50	0.00	N	Arm 5 Ahead	Inf	100.0 %	2105	2105
3/3 (Holyhead Rd (SE))	3.50	0.00	Y	Arm 6 Right	32.00	100.0 %	1877	1877
4/1 (Wrottesley Park Rd)	3.00	0.00	Y	Arm 5 Left	21.00	25.8 %	1880	1880
				Arm 6 Ahead	Inf	74.2 %		
4/2 (Wrottesley Park Rd)	3.00	0.00	Y	Arm 7 Right	10.00	100.0 %	1665	1665
5/1	Infinite Saturation Flow						Inf	Inf
5/2	Infinite Saturation Flow						Inf	Inf
6/1	Infinite Saturation Flow						Inf	Inf
7/1	Infinite Saturation Flow						Inf	Inf
8/1	Infinite Saturation Flow						Inf	Inf
8/2	Infinite Saturation Flow						Inf	Inf

**Scenario 1: 'AM32+Dev' (FG2: 'AM 2032 + Development', Plan 1: '12345')**

**Stage Sequence Diagram**

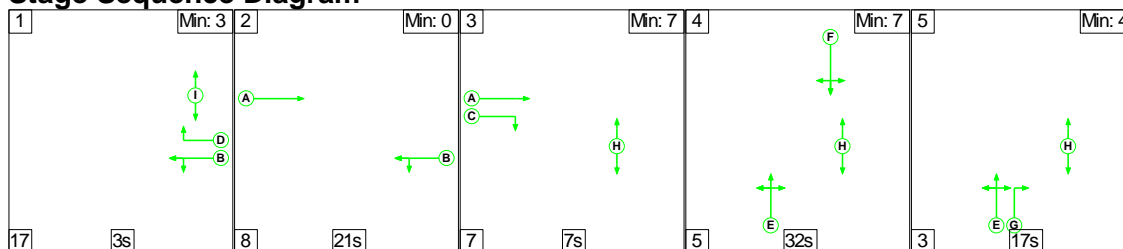

**Stage Timings**

Stage	1	2	3	4	5
Duration	3	21	7	32	17
Change Point	0	20	49	63	100

**Signal Timings Diagram**

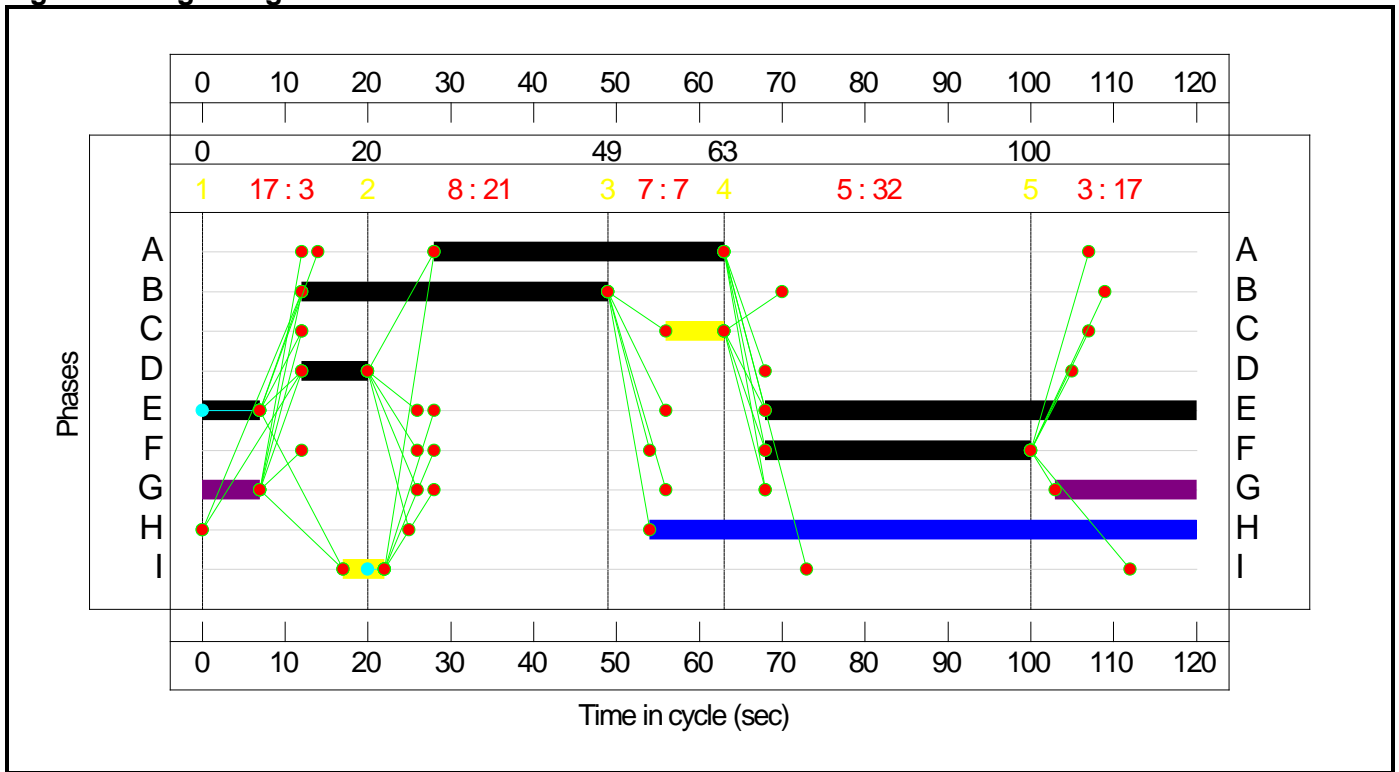

**Network Layout Diagram**

Results For Scenario: AM32+Dev		
Cycle Time: 120	PRC: -3.0%	Tot Delay (pcuHr): 37.83

**Heath House Ln**  
 PRC: -3.0 %  
 Total Traffic Delay: 37.8 pcuHr

**OPTION D**

Based on Option D from Job 16046. However, parameters updated based on latest drawing from SCC.

Intergreens re-measured according to Chapter 6 in Traffic Signs Manual

Cycle time reduced to 100s in PM, as 150s provides little extra benefit.

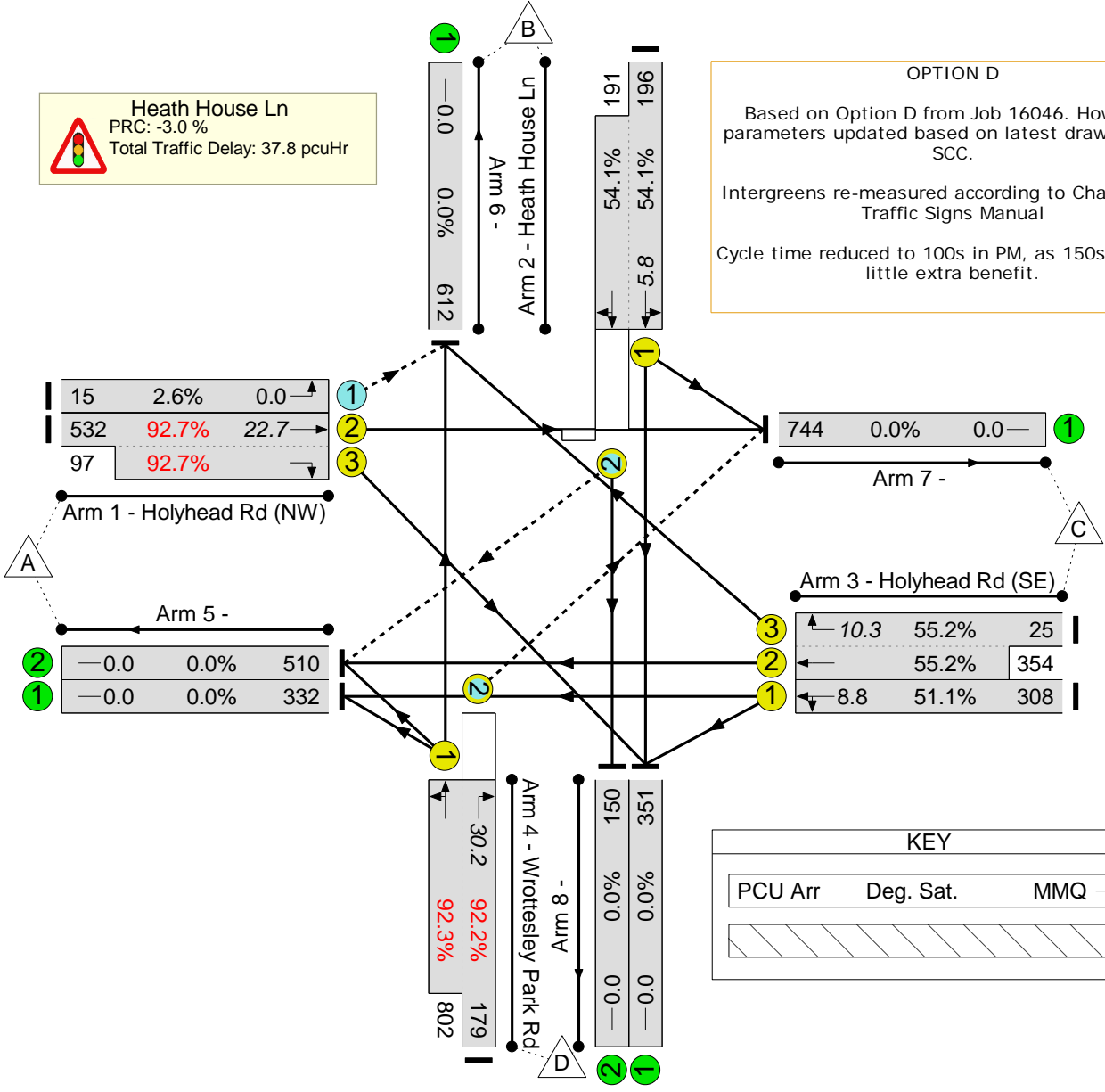

KEY		
PCU Arr	Deg. Sat.	MMQ
(Symbol for hatched box)		

**Network Results**

Item	Lane Description	Lane Type	Controller Stream	Position In Filtered Route	Full Phase	Arrow Phase	Num Greens	Total Green (s)	Arrow Green (s)	Demand Flow (pcu)	Sat Flow (pcu/Hr)	Capacity (pcu)	Deg Sat (%)
Network: Option D Update	-	-	N/A	-	-		-	-	-	-	-	-	92.7%
Heath House Ln	-	-	N/A	-	-		-	-	-	-	-	-	92.7%
1/1	Holyhead Rd (NW) Left	O	N/A	N/A	-		-	-	-	15	Inf	584	2.6%
1/2+1/3	Holyhead Rd (NW) Ahead Right	U	N/A	N/A	A C		1	35:7	-	629	1965:1899	574+105	92.7 : 92.7%
2/1+2/2	Heath House Ln Right Left Ahead	U+O	N/A	N/A	F		1	32	-	387	1945:1904	362+353	54.1 : 54.1%
3/1	Holyhead Rd (SE) Ahead Left	U	N/A	N/A	B		1	37	-	308	1905	603	51.1%
3/3+3/2	Holyhead Rd (SE) Ahead Right	U	N/A	N/A	D B		1	8:37	-	379	1877:2105	45+641	55.2 : 55.2%
4/2+4/1	Wrottesley Park Rd Left Ahead Right	O+U	N/A	N/A	E	G	1	59	24	981	1665:1877	194+869	92.2 : 92.3%
5/1		U	N/A	N/A	-		-	-	-	332	Inf	Inf	0.0%
5/2		U	N/A	N/A	-		-	-	-	510	Inf	Inf	0.0%
6/1		U	N/A	N/A	-		-	-	-	612	Inf	Inf	0.0%
7/1		U	N/A	N/A	-		-	-	-	744	Inf	Inf	0.0%
8/1		U	N/A	N/A	-		-	-	-	351	Inf	Inf	0.0%
8/2		U	N/A	N/A	-		-	-	-	150	Inf	Inf	0.0%

Item	Arriving (pcu)	Leaving (pcu)	Turners In Gaps (pcu)	Turners When Unopposed (pcu)	Turners In Intergreen (pcu)	Uniform Delay (pcuHr)	Rand + Oversat Delay (pcuHr)	Storage Area Uniform Delay (pcuHr)	Total Delay (pcuHr)	Av. Delay Per PCU (s/pcu)	Max. Back of Uniform Queue (pcu)	Rand + Oversat Queue (pcu)	Mean Max Queue (pcu)
<b>Network: Option D Update</b>	-	-	188	41	6	25.0	12.2	0.6	37.8	-	-	-	-
<b>Heath House Ln</b>	-	-	188	41	6	25.0	12.2	0.6	37.8	-	-	-	-
1/1	15	15	9	6	0	0.0	0.0	-	0.0	3.2	0.0	0.0	0.0
1/2+1/3	629	629	-	-	-	7.4	5.2	-	12.7	72.5	17.4	5.2	22.7
2/1+2/2	387	387	40	0	1	3.8	0.6	0.2	4.5	42.2	5.2	0.6	5.8
3/1	308	308	-	-	-	2.9	0.5	-	3.4	39.5	8.3	0.5	8.8
3/3+3/2	379	379	-	-	-	3.7	0.6	-	4.3	40.7	9.6	0.6	10.3
4/2+4/1	981	981	140	34	4	7.2	5.3	0.4	12.9	47.5	25.0	5.3	30.2
5/1	332	332	-	-	-	0.0	0.0	-	0.0	0.0	0.0	0.0	0.0
5/2	510	510	-	-	-	0.0	0.0	-	0.0	0.0	0.0	0.0	0.0
6/1	612	612	-	-	-	0.0	0.0	-	0.0	0.0	0.0	0.0	0.0
7/1	744	744	-	-	-	0.0	0.0	-	0.0	0.0	0.0	0.0	0.0
8/1	351	351	-	-	-	0.0	0.0	-	0.0	0.0	0.0	0.0	0.0
8/2	150	150	-	-	-	0.0	0.0	-	0.0	0.0	0.0	0.0	0.0
C1      PRC for Signalled Lanes (%): -3.0      Total Delay for Signalled Lanes (pcuHr): 37.81      Cycle Time (s): 120 PRC Over All Lanes (%): -3.0      Total Delay Over All Lanes(pcuHr): 37.83													

Scenario 2: 'AM32+Dev+Rich' (FG3: 'AM 2032 + Development + Richborough', Plan 1: '12345')

**Stage Sequence Diagram**

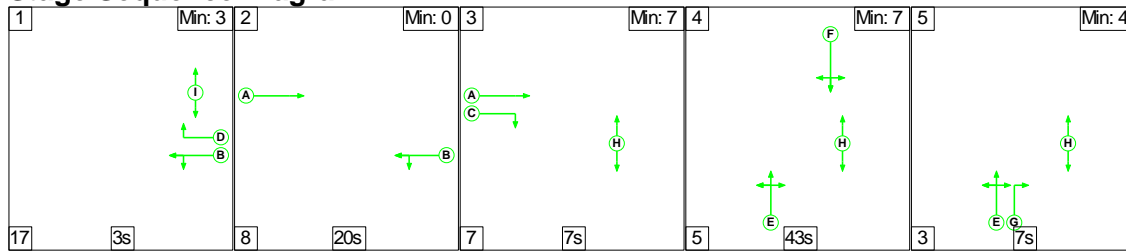

**Stage Timings**

Stage	1	2	3	4	5
Duration	3	20	7	43	7
Change Point	0	20	48	62	110

**Signal Timings Diagram**

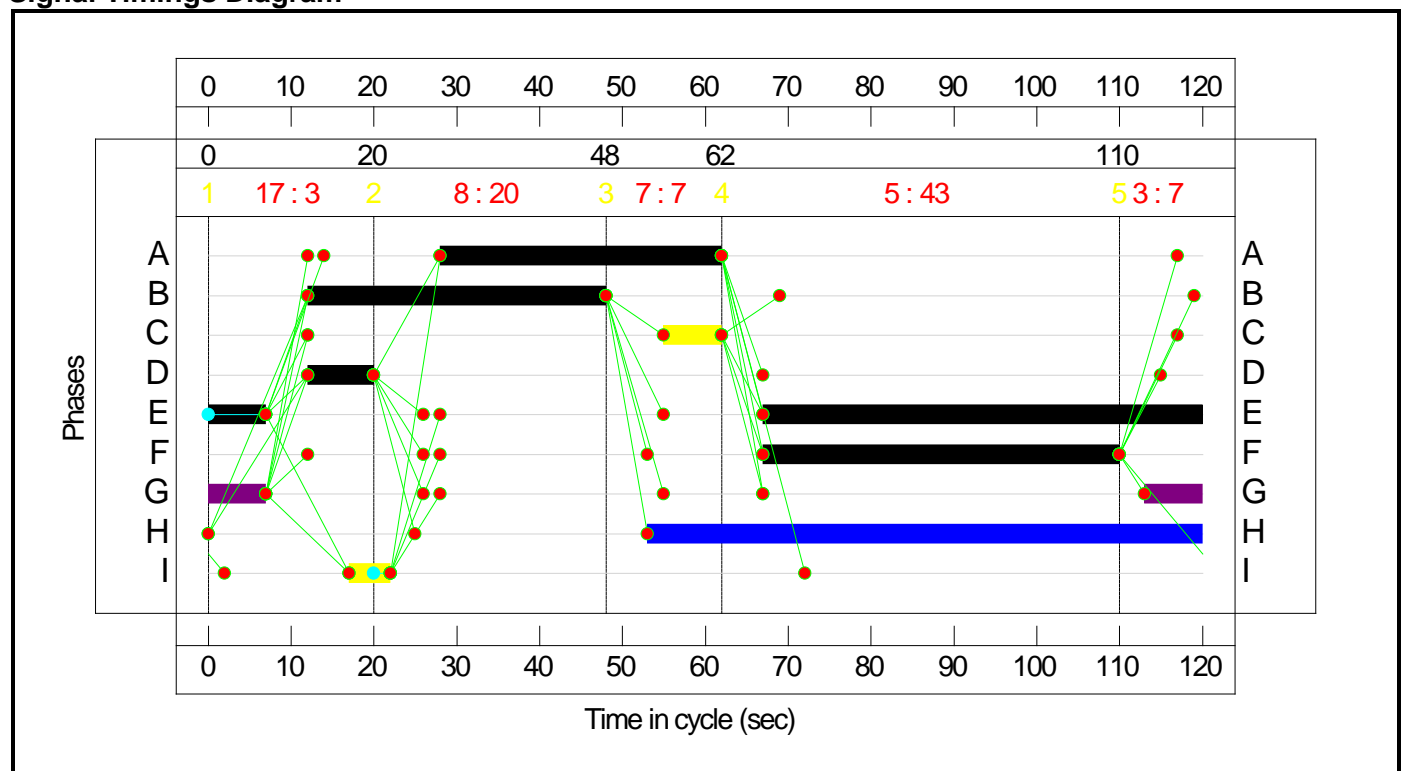

**Network Layout Diagram**

Results For Scenario: AM32+Dev+Rich		
Cycle Time: 120	PRC: -5.6%	Tot Delay (pcuHr): 40.64

**Heath House Ln**  
 PRC: -5.6 %  
 Total Traffic Delay: 40.6 pcuHr

**OPTION D**

Based on Option D from Job 16046. However, parameters updated based on latest drawing from SCC.

Intergreens re-measured according to Chapter 6 in Traffic Signs Manual

Cycle time reduced to 100s in PM, as 150s provides little extra benefit.

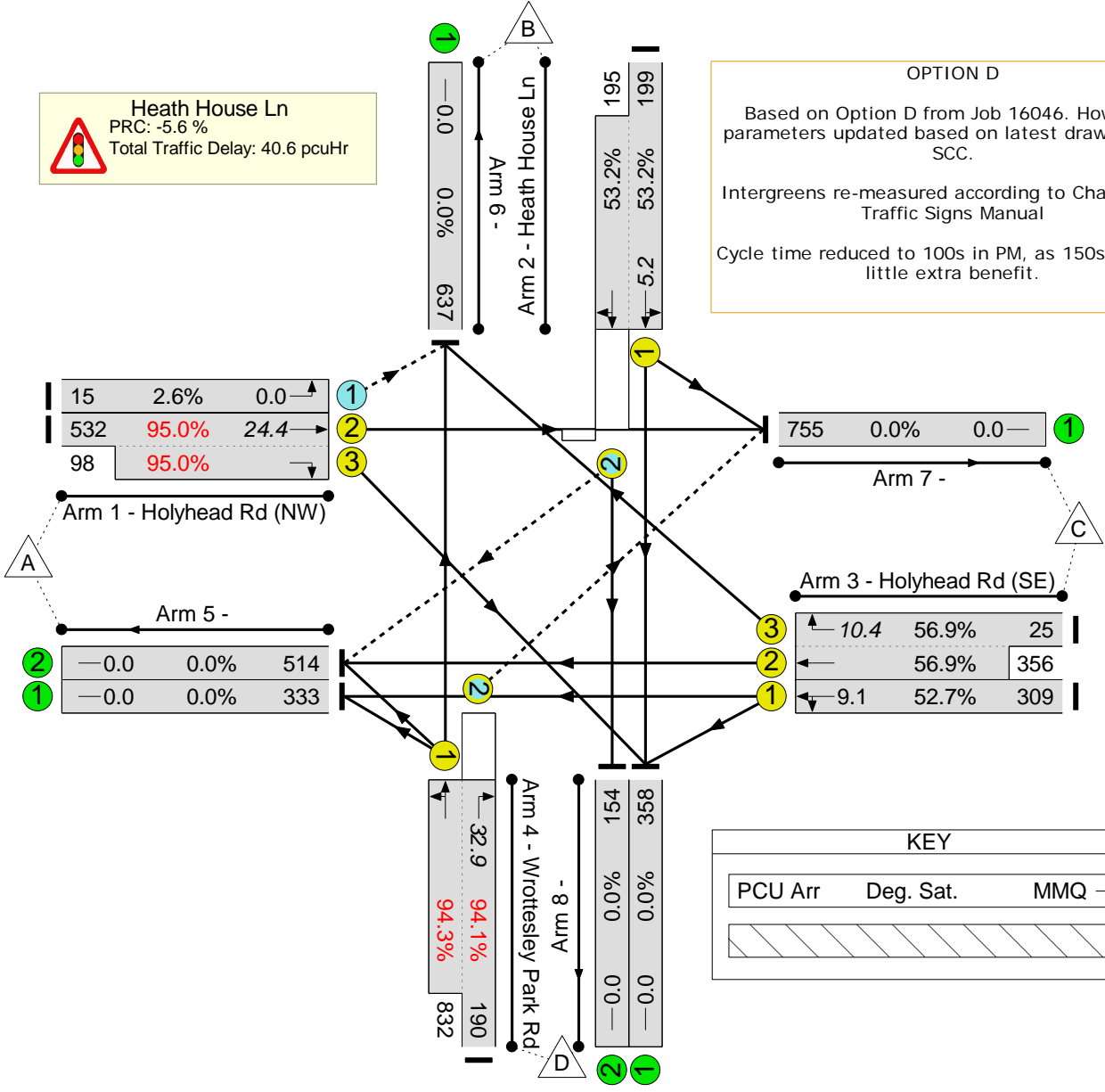

**Network Results**

Item	Lane Description	Lane Type	Controller Stream	Position In Filtered Route	Full Phase	Arrow Phase	Num Greens	Total Green (s)	Arrow Green (s)	Demand Flow (pcu)	Sat Flow (pcu/Hr)	Capacity (pcu)	Deg Sat (%)
<b>Network: Option D Update</b>	-	-	N/A	-	-		-	-	-	-	-	-	95.0%
<b>Heath House Ln</b>	-	-	N/A	-	-		-	-	-	-	-	-	95.0%
1/1	Holyhead Rd (NW) Left	O	N/A	N/A	-		-	-	-	15	Inf	578	2.6%
1/2+1/3	Holyhead Rd (NW) Ahead Right	U	N/A	N/A	A C		1	34:7	-	630	1965:1899	560+103	95.0 : 95.0%
2/1+2/2	Heath House Ln Right Left Ahead	U+O	N/A	N/A	F		1	43	-	394	1946:1905	374+367	53.2 : 53.2%
3/1	Holyhead Rd (SE) Ahead Left	U	N/A	N/A	B		1	36	-	309	1903	587	52.7%
3/3+3/2	Holyhead Rd (SE) Ahead Right	U	N/A	N/A	D B		1	8:36	-	381	1877:2105	44+625	56.9 : 56.9%
4/2+4/1	Wrottesley Park Rd Left Ahead Right	O+U	N/A	N/A	E	G	1	60	14	1022	1665:1877	202+882	94.1 : 94.3%
5/1		U	N/A	N/A	-		-	-	-	333	Inf	Inf	0.0%
5/2		U	N/A	N/A	-		-	-	-	514	Inf	Inf	0.0%
6/1		U	N/A	N/A	-		-	-	-	637	Inf	Inf	0.0%
7/1		U	N/A	N/A	-		-	-	-	755	Inf	Inf	0.0%
8/1		U	N/A	N/A	-		-	-	-	358	Inf	Inf	0.0%
8/2		U	N/A	N/A	-		-	-	-	154	Inf	Inf	0.0%



Item	Arriving (pcu)	Leaving (pcu)	Turners In Gaps (pcu)	Turners When Unopposed (pcu)	Turners In Intergreen (pcu)	Uniform Delay (pcuHr)	Rand + Oversat Delay (pcuHr)	Storage Area Uniform Delay (pcuHr)	Total Delay (pcuHr)	Av. Delay Per PCU (s/pcu)	Max. Back of Uniform Queue (pcu)	Rand + Oversat Queue (pcu)	Mean Max Queue (pcu)
<b>Network: Option D Update</b>	-	-	213	27	6	24.8	15.3	0.5	40.6	-	-	-	-
<b>Heath House Ln</b>	-	-	213	27	6	24.8	15.3	0.5	40.6	-	-	-	-
1/1	15	15	9	6	0	0.0	0.0	-	0.0	3.2	0.0	0.0	0.0
1/2+1/3	630	630	-	-	-	7.6	6.7	-	14.3	82.0	17.6	6.7	24.4
2/1+2/2	394	394	40	0	1	2.9	0.6	0.1	3.6	33.3	4.6	0.6	5.2
3/1	309	309	-	-	-	2.9	0.6	-	3.5	40.7	8.5	0.6	9.1
3/3+3/2	381	381	-	-	-	3.8	0.7	-	4.4	41.9	9.8	0.7	10.4
4/2+4/1	1022	1022	165	21	5	7.5	6.8	0.4	14.7	51.8	26.1	6.8	32.9
5/1	333	333	-	-	-	0.0	0.0	-	0.0	0.0	0.0	0.0	0.0
5/2	514	514	-	-	-	0.0	0.0	-	0.0	0.0	0.0	0.0	0.0
6/1	637	637	-	-	-	0.0	0.0	-	0.0	0.0	0.0	0.0	0.0
7/1	755	755	-	-	-	0.0	0.0	-	0.0	0.0	0.0	0.0	0.0
8/1	358	358	-	-	-	0.0	0.0	-	0.0	0.0	0.0	0.0	0.0
8/2	154	154	-	-	-	0.0	0.0	-	0.0	0.0	0.0	0.0	0.0
C1                      PRC for Signalled Lanes (%): -5.6                      Total Delay for Signalled Lanes (pcuHr): 40.63                      Cycle Time (s): 120 PRC Over All Lanes (%): -5.6                      Total Delay Over All Lanes(pcuHr): 40.64													

Scenario 3: 'AM32+LP+Rich+IM' (FG13: 'AM 2032 (All)', Plan 1: '12345')

**Stage Sequence Diagram**

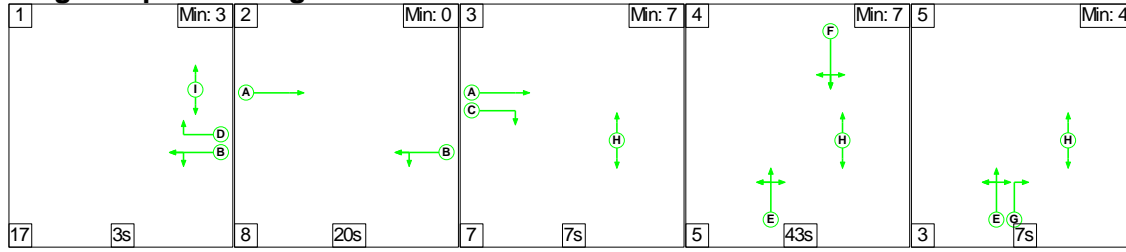

**Stage Timings**

Stage	1	2	3	4	5
Duration	3	20	7	43	7
Change Point	0	20	48	62	110

**Signal Timings Diagram**

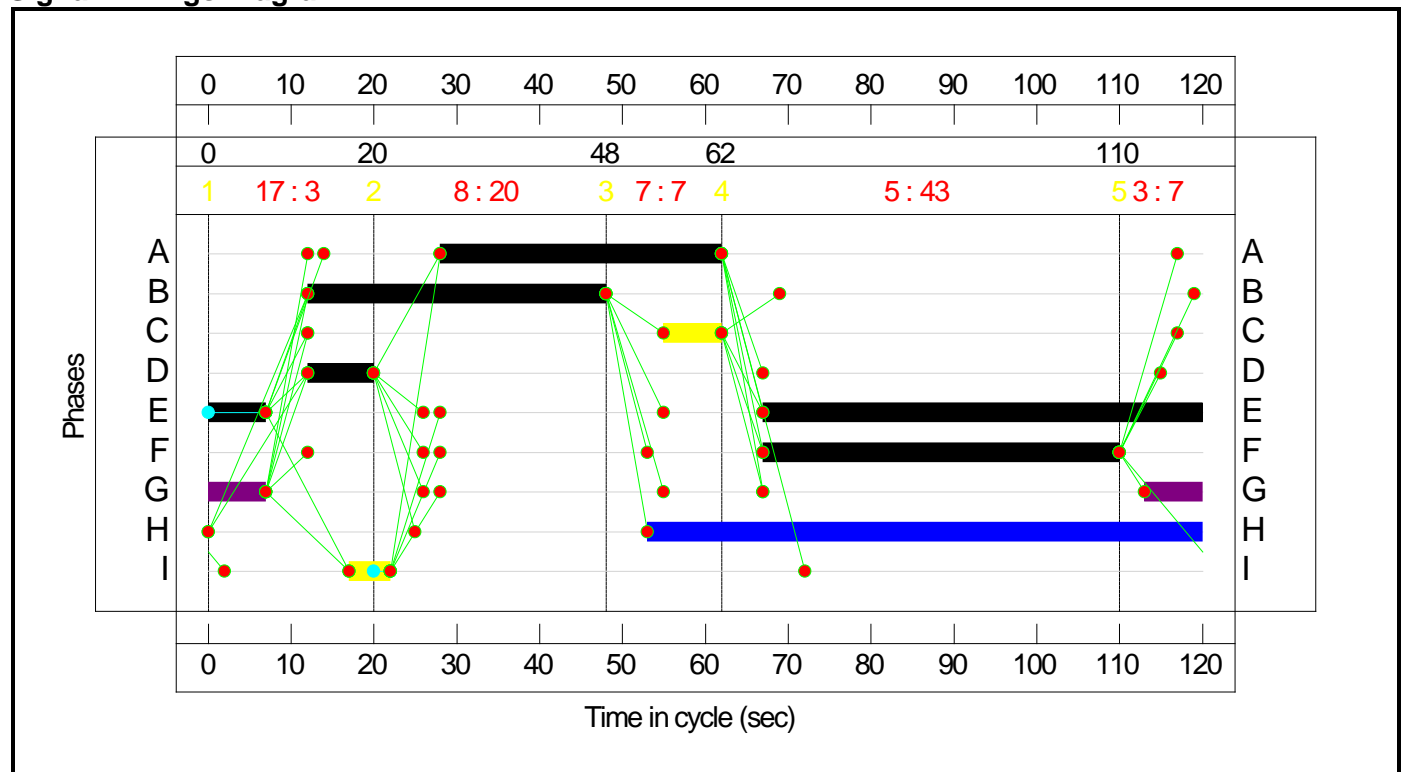

**Network Layout Diagram**

Results For Scenario: AM32+LP+Rich+IM		
Cycle Time: 120	PRC: -6.4%	Tot Delay (pcuHr): 42.50

**Heath House Ln**  
 PRC: -6.4 %  
 Total Traffic Delay: 42.5 pcuHr

**OPTION D**

Based on Option D from Job 16046. However, parameters updated based on latest drawing from SCC.

Intergreens re-measured according to Chapter 6 in Traffic Signs Manual

Cycle time reduced to 100s in PM, as 150s provides little extra benefit.

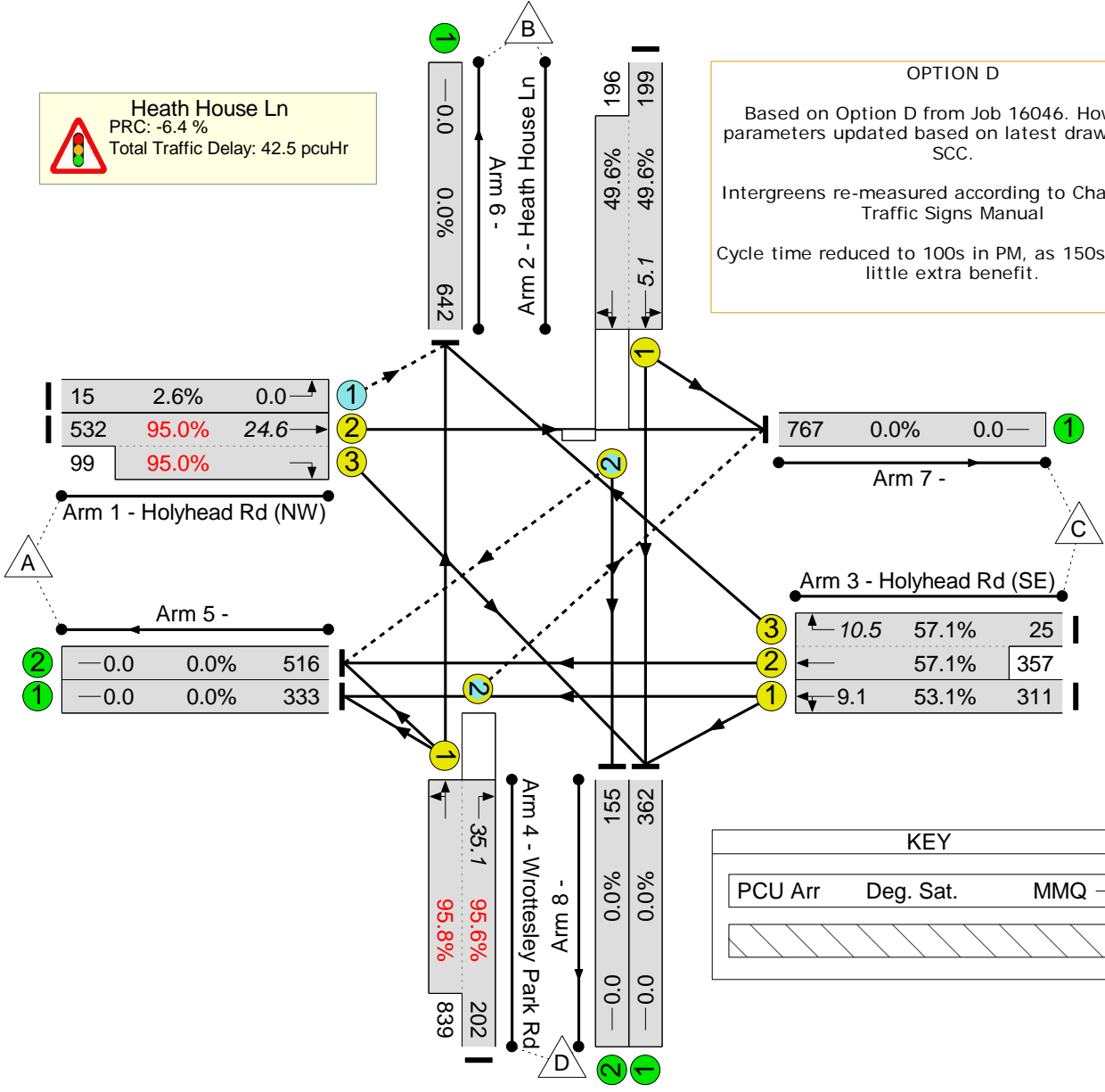

KEY		
PCU Arr	Deg. Sat.	MMQ →

**Network Results**

Item	Lane Description	Lane Type	Controller Stream	Position In Filtered Route	Full Phase	Arrow Phase	Num Greens	Total Green (s)	Arrow Green (s)	Demand Flow (pcu)	Sat Flow (pcu/Hr)	Capacity (pcu)	Deg Sat (%)
Network: Option D Update	-	-	N/A	-	-		-	-	-	-	-	-	95.8%
Heath House Ln	-	-	N/A	-	-		-	-	-	-	-	-	95.8%
1/1	Holyhead Rd (NW) Left	O	N/A	N/A	-		-	-	-	15	Inf	577	2.6%
1/2+1/3	Holyhead Rd (NW) Ahead Right	U	N/A	N/A	A C		1	34:7	-	631	1965:1899	560+104	95.0 : 95.0%
2/1+2/2	Heath House Ln Right Left Ahead	U+O	N/A	N/A	F		1	43	-	395	1946:1905	402+396	49.6 : 49.6%
3/1	Holyhead Rd (SE) Ahead Left	U	N/A	N/A	B		1	36	-	311	1901	586	53.1%
3/3+3/2	Holyhead Rd (SE) Ahead Right	U	N/A	N/A	D B		1	8:36	-	382	1877:2105	44+625	57.1 : 57.1%
4/2+4/1	Wrottesley Park Rd Left Ahead Right	O+U	N/A	N/A	E	G	1	60	14	1041	1665:1877	211+876	95.6 : 95.8%
5/1		U	N/A	N/A	-		-	-	-	333	Inf	Inf	0.0%
5/2		U	N/A	N/A	-		-	-	-	516	Inf	Inf	0.0%
6/1		U	N/A	N/A	-		-	-	-	642	Inf	Inf	0.0%
7/1		U	N/A	N/A	-		-	-	-	767	Inf	Inf	0.0%
8/1		U	N/A	N/A	-		-	-	-	362	Inf	Inf	0.0%
8/2		U	N/A	N/A	-		-	-	-	155	Inf	Inf	0.0%

Item	Arriving (pcu)	Leaving (pcu)	Turners In Gaps (pcu)	Turners When Unopposed (pcu)	Turners In Intergreen (pcu)	Uniform Delay (pcuHr)	Rand + Oversat Delay (pcuHr)	Storage Area Uniform Delay (pcuHr)	Total Delay (pcuHr)	Av. Delay Per PCU (s/pcu)	Max. Back of Uniform Queue (pcu)	Rand + Oversat Queue (pcu)	Mean Max Queue (pcu)
<b>Network: Option D Update</b>	-	-	223	28	6	25.1	16.8	0.6	42.5	-	-	-	-
<b>Heath House Ln</b>	-	-	223	28	6	25.1	16.8	0.6	42.5	-	-	-	-
1/1	15	15	9	6	0	0.0	0.0	-	0.0	3.2	0.0	0.0	0.0
1/2+1/3	631	631	-	-	-	7.6	6.8	-	14.4	82.1	17.8	6.8	24.6
2/1+2/2	395	395	40	0	1	2.9	0.5	0.1	3.6	32.5	4.6	0.5	5.1
3/1	311	311	-	-	-	3.0	0.6	-	3.5	40.8	8.6	0.6	9.1
3/3+3/2	382	382	-	-	-	3.8	0.7	-	4.5	42.0	9.8	0.7	10.5
4/2+4/1	1041	1041	175	22	5	7.8	8.3	0.4	16.5	57.2	26.8	8.3	35.1
5/1	333	333	-	-	-	0.0	0.0	-	0.0	0.0	0.0	0.0	0.0
5/2	516	516	-	-	-	0.0	0.0	-	0.0	0.0	0.0	0.0	0.0
6/1	642	642	-	-	-	0.0	0.0	-	0.0	0.0	0.0	0.0	0.0
7/1	767	767	-	-	-	0.0	0.0	-	0.0	0.0	0.0	0.0	0.0
8/1	362	362	-	-	-	0.0	0.0	-	0.0	0.0	0.0	0.0	0.0
8/2	155	155	-	-	-	0.0	0.0	-	0.0	0.0	0.0	0.0	0.0
C1      PRC for Signalled Lanes (%): -6.4      Total Delay for Signalled Lanes (pcuHr): 42.49      Cycle Time (s): 120 PRC Over All Lanes (%): -6.4      Total Delay Over All Lanes(pcuHr): 42.50													

**Scenario 4: 'PM32+Dev'** (FG5: 'PM 2032 + Development', Plan 1: '12345')

**Stage Sequence Diagram**

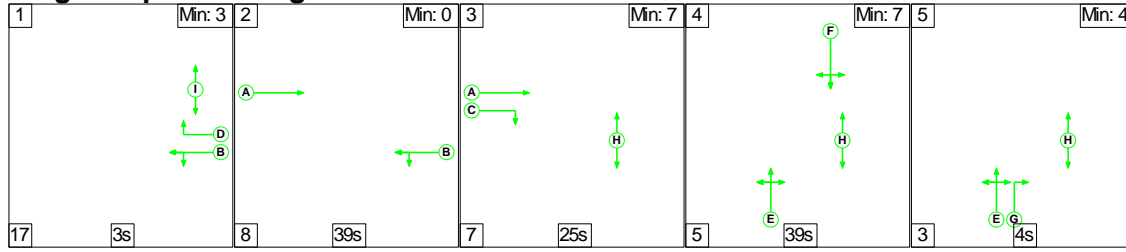

**Stage Timings**

Stage	1	2	3	4	5
Duration	3	39	25	39	4
Change Point	0	20	67	99	143

**Signal Timings Diagram**

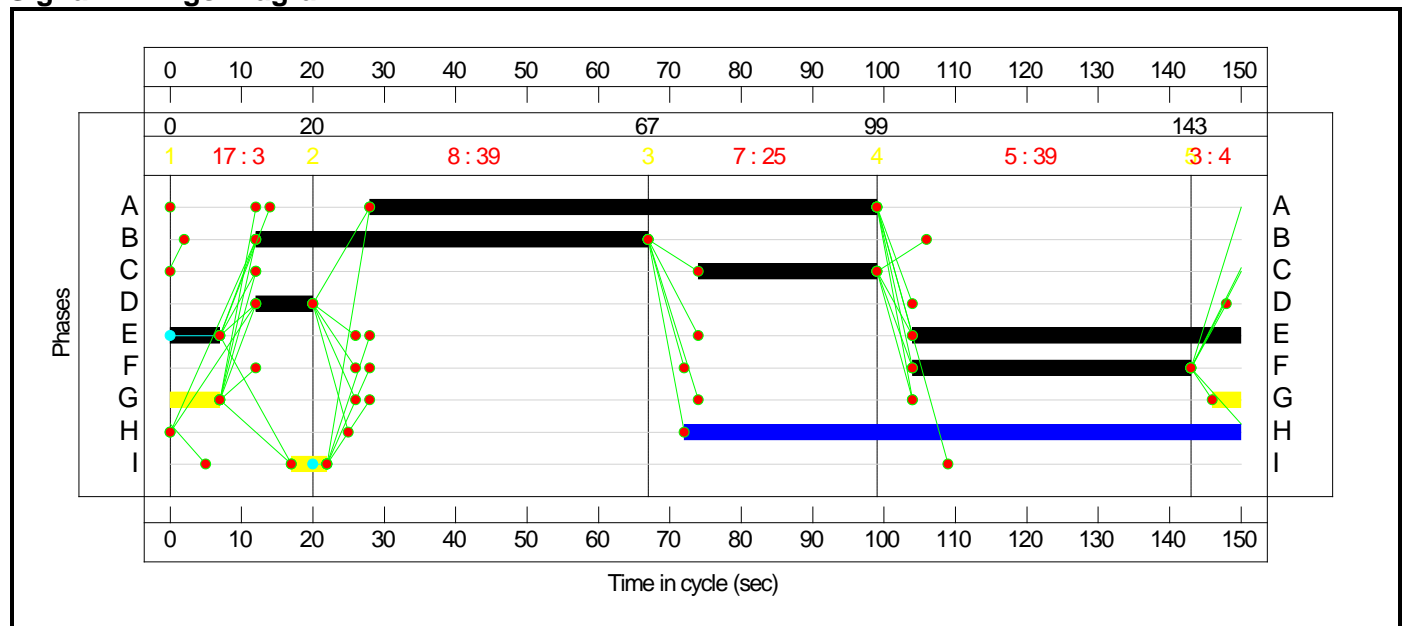

**Network Layout Diagram**

Results For Scenario: PM32+Dev		
Cycle Time: 150	PRC: 19.7%	Tot Delay (pcuHr): 37.73

**Heath House Ln**  
 PRC: 19.7 %  
 Total Traffic Delay: 37.7 pcuHr

**OPTION D**

Based on Option D from Job 16046. However, parameters updated based on latest drawing from SCC.

Intergreens re-measured according to Chapter 6 in Traffic Signs Manual

Cycle time reduced to 100s in PM, as 150s provides little extra benefit.

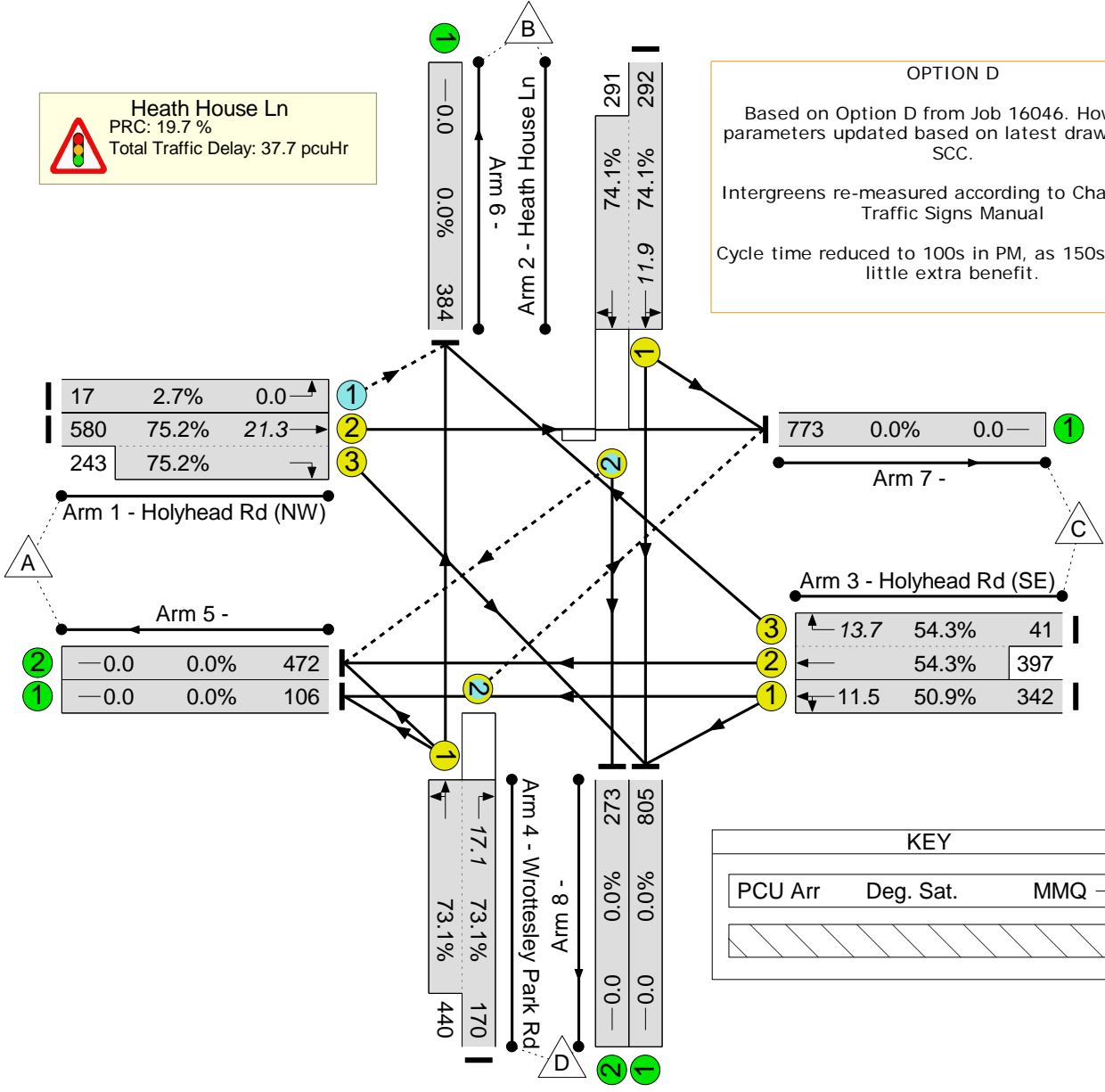

KEY		
PCU Arr	Deg. Sat.	MMQ

**Network Results**

Item	Lane Description	Lane Type	Controller Stream	Position In Filtered Route	Full Phase	Arrow Phase	Num Greens	Total Green (s)	Arrow Green (s)	Demand Flow (pcu)	Sat Flow (pcu/Hr)	Capacity (pcu)	Deg Sat (%)
<b>Network: Option D Update</b>	-	-	N/A	-	-		-	-	-	-	-	-	75.2%
<b>Heath House Ln</b>	-	-	N/A	-	-		-	-	-	-	-	-	75.2%
1/1	Holyhead Rd (NW) Left	O	N/A	N/A	-		-	-	-	17	Inf	634	2.7%
1/2+1/3	Holyhead Rd (NW) Ahead Right	U	N/A	N/A	A C		1	71:25	-	823	1965:1899	771+323	75.2 : 75.2%
2/1+2/2	Heath House Ln Right Left Ahead	U+O	N/A	N/A	F		1	39	-	583	1956:1947	394+393	74.1 : 74.1%
3/1	Holyhead Rd (SE) Ahead Left	U	N/A	N/A	B		1	55	-	342	1800	672	50.9%
3/3+3/2	Holyhead Rd (SE) Ahead Right	U	N/A	N/A	D B		1	8:55	-	438	1877:2105	75+730	54.3 : 54.3%
4/2+4/1	Wrottesley Park Rd Left Ahead Right	O+U	N/A	N/A	E	G	1	53	11	610	1665:1880	232+602	73.1 : 73.1%
5/1		U	N/A	N/A	-		-	-	-	106	Inf	Inf	0.0%
5/2		U	N/A	N/A	-		-	-	-	472	Inf	Inf	0.0%
6/1		U	N/A	N/A	-		-	-	-	384	Inf	Inf	0.0%
7/1		U	N/A	N/A	-		-	-	-	773	Inf	Inf	0.0%
8/1		U	N/A	N/A	-		-	-	-	805	Inf	Inf	0.0%
8/2		U	N/A	N/A	-		-	-	-	273	Inf	Inf	0.0%



Item	Arriving (pcu)	Leaving (pcu)	Turners In Gaps (pcu)	Turners When Unopposed (pcu)	Turners In Intergreen (pcu)	Uniform Delay (pcuHr)	Rand + Oversat Delay (pcuHr)	Storage Area Uniform Delay (pcuHr)	Total Delay (pcuHr)	Av. Delay Per PCU (s/pcu)	Max. Back of Uniform Queue (pcu)	Rand + Oversat Queue (pcu)	Mean Max Queue (pcu)
<b>Network: Option D Update</b>	-	-	121	80	4	31.6	5.4	0.8	37.7	-	-	-	-
<b>Heath House Ln</b>	-	-	121	80	4	31.6	5.4	0.8	37.7	-	-	-	-
1/1	17	17	7	10	0	0.0	0.0	-	0.0	2.9	0.0	0.0	0.0
1/2+1/3	823	823	-	-	-	8.6	1.5	-	10.1	44.3	19.8	1.5	21.3
2/1+2/2	583	583	18	0	0	7.7	1.4	0.1	9.2	56.5	10.5	1.4	11.9
3/1	342	342	-	-	-	3.5	0.5	-	4.0	41.8	11.0	0.5	11.5
3/3+3/2	438	438	-	-	-	4.9	0.6	-	5.5	45.1	13.1	0.6	13.7
4/2+4/1	610	610	96	70	3	6.9	1.3	0.7	9.0	53.0	15.8	1.3	17.1
5/1	106	106	-	-	-	0.0	0.0	-	0.0	0.0	0.0	0.0	0.0
5/2	472	472	-	-	-	0.0	0.0	-	0.0	0.0	0.0	0.0	0.0
6/1	384	384	-	-	-	0.0	0.0	-	0.0	0.0	0.0	0.0	0.0
7/1	773	773	-	-	-	0.0	0.0	-	0.0	0.0	0.0	0.0	0.0
8/1	805	805	-	-	-	0.0	0.0	-	0.0	0.0	0.0	0.0	0.0
8/2	273	273	-	-	-	0.0	0.0	-	0.0	0.0	0.0	0.0	0.0
C1			PRC for Signalled Lanes (%):		19.7	Total Delay for Signalled Lanes (pcuHr):		37.72	Cycle Time (s): 150				
			PRC Over All Lanes (%):		19.7	Total Delay Over All Lanes(pcuHr):		37.73					

Scenario 5: 'PM32+Dev+Rich' (FG6: 'PM 2032 + Development + Richborough', Plan 1: '12345')

**Stage Sequence Diagram**

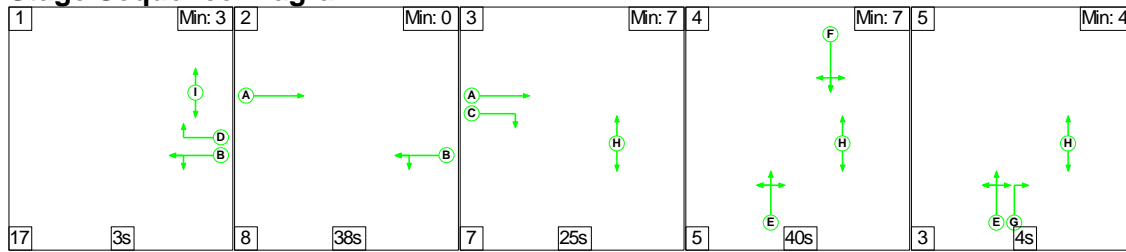

**Stage Timings**

Stage	1	2	3	4	5
Duration	3	38	25	40	4
Change Point	0	20	66	98	143

**Signal Timings Diagram**

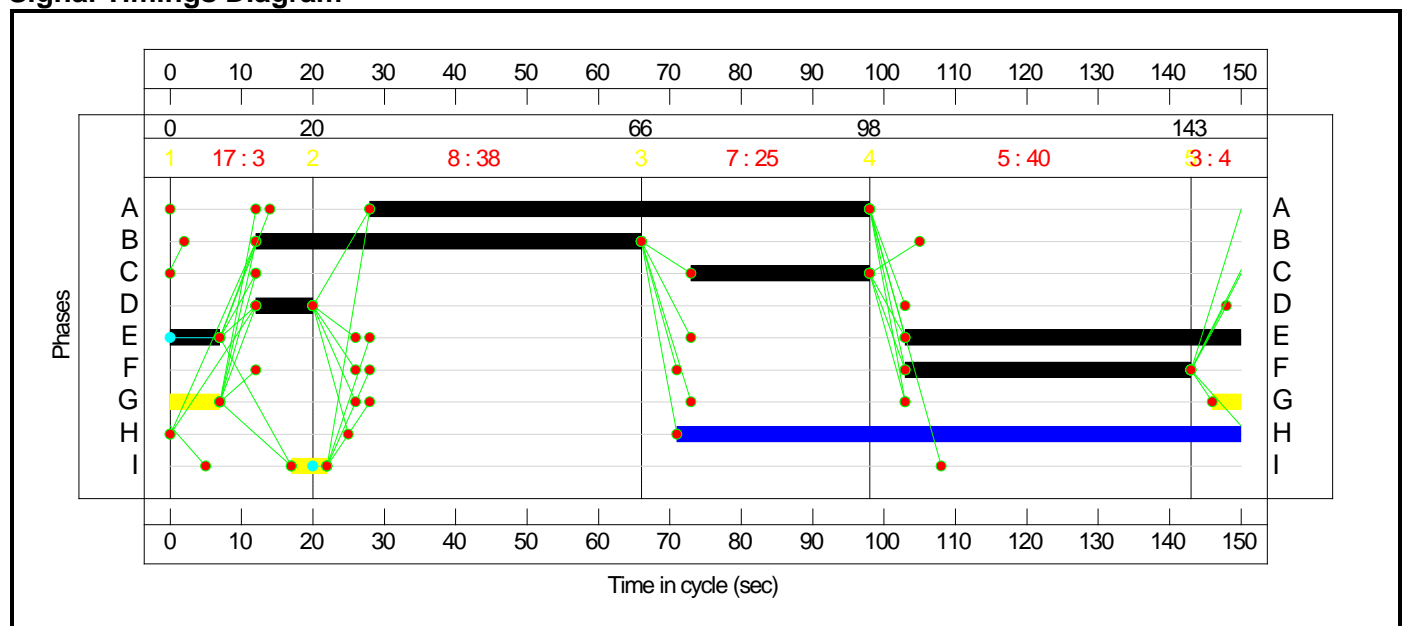

**Network Layout Diagram**

Results For Scenario: PM32+Dev+Rich		
Cycle Time: 150	PRC: 17.9%	Tot Delay (pcuHr): 39.17

**Heath House Ln**  
 PRC: 17.9 %  
 Total Traffic Delay: 39.2 pcuHr

**OPTION D**

Based on Option D from Job 16046. However, parameters updated based on latest drawing from SCC.

Intergreens re-measured according to Chapter 6 in Traffic Signs Manual

Cycle time reduced to 100s in PM, as 150s provides little extra benefit.

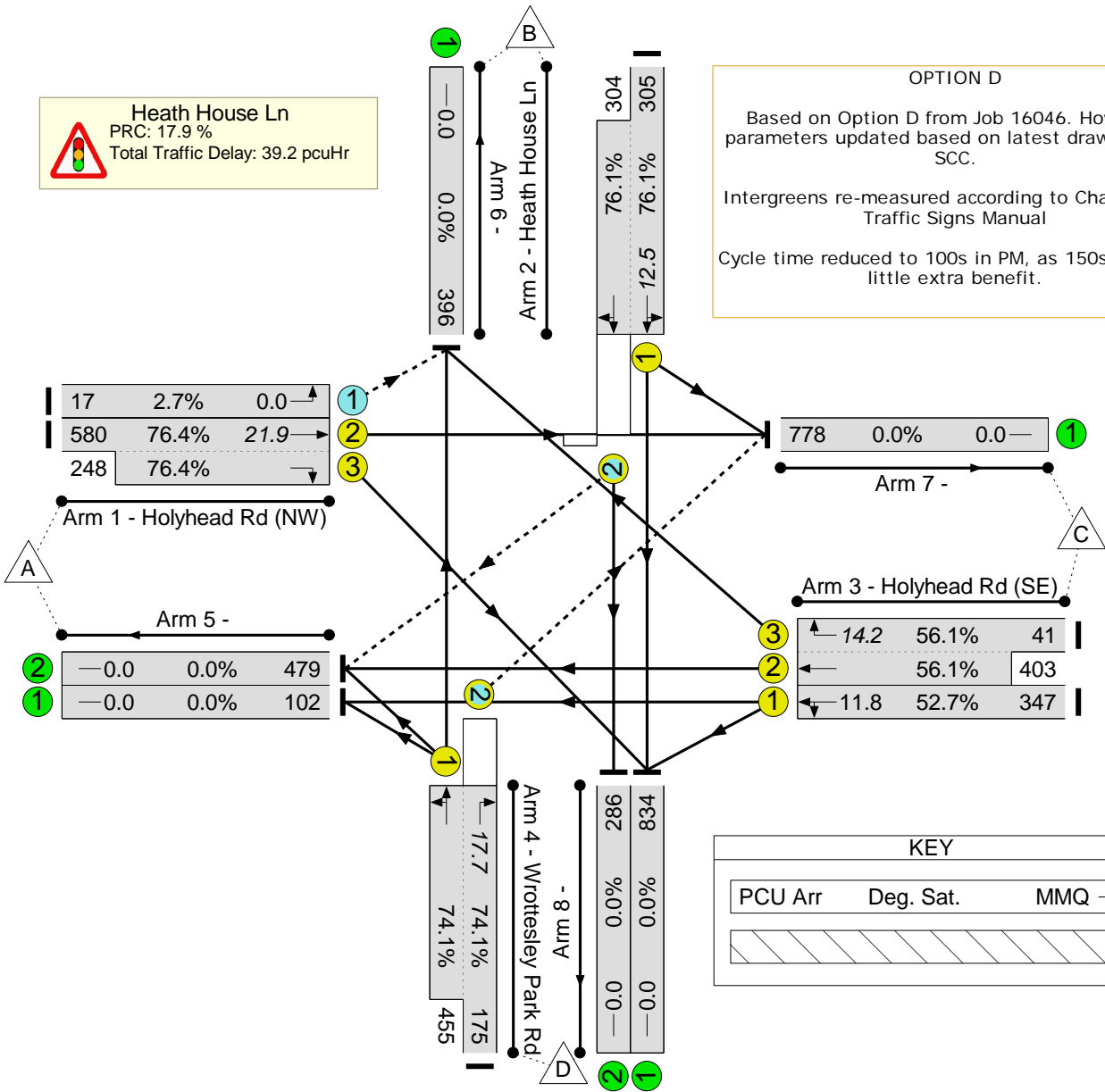

**Network Results**

Item	Lane Description	Lane Type	Controller Stream	Position In Filtered Route	Full Phase	Arrow Phase	Num Greens	Total Green (s)	Arrow Green (s)	Demand Flow (pcu)	Sat Flow (pcu/Hr)	Capacity (pcu)	Deg Sat (%)
<b>Network: Option D Update</b>	-	-	N/A	-	-		-	-	-	-	-	-	76.4%
<b>Heath House Ln</b>	-	-	N/A	-	-		-	-	-	-	-	-	76.4%
1/1	Holyhead Rd (NW) Left	O	N/A	N/A	-		-	-	-	17	Inf	632	2.7%
1/2+1/3	Holyhead Rd (NW) Ahead Right	U	N/A	N/A	A C		1	70:25	-	828	1965:1899	760+325	76.4 : 76.4%
2/1+2/2	Heath House Ln Right Left Ahead	U+O	N/A	N/A	F		1	40	-	609	1956:1948	401+400	76.1 : 76.1%
3/1	Holyhead Rd (SE) Ahead Left	U	N/A	N/A	B		1	54	-	347	1796	659	52.7%
3/3+3/2	Holyhead Rd (SE) Ahead Right	U	N/A	N/A	D B		1	8:54	-	444	1877:2105	73+719	56.1 : 56.1%
4/2+4/1	Wrottesley Park Rd Left Ahead Right	O+U	N/A	N/A	E	G	1	54	11	630	1665:1880	236+614	74.1 : 74.1%
5/1		U	N/A	N/A	-		-	-	-	102	Inf	Inf	0.0%
5/2		U	N/A	N/A	-		-	-	-	479	Inf	Inf	0.0%
6/1		U	N/A	N/A	-		-	-	-	396	Inf	Inf	0.0%
7/1		U	N/A	N/A	-		-	-	-	778	Inf	Inf	0.0%
8/1		U	N/A	N/A	-		-	-	-	834	Inf	Inf	0.0%
8/2		U	N/A	N/A	-		-	-	-	286	Inf	Inf	0.0%

Item	Arriving (pcu)	Leaving (pcu)	Turners In Gaps (pcu)	Turners When Unopposed (pcu)	Turners In Intergreen (pcu)	Uniform Delay (pcuHr)	Rand + Oversat Delay (pcuHr)	Storage Area Uniform Delay (pcuHr)	Total Delay (pcuHr)	Av. Delay Per PCU (s/pcu)	Max. Back of Uniform Queue (pcu)	Rand + Oversat Queue (pcu)	Mean Max Queue (pcu)
<b>Network: Option D Update</b>	-	-	118	88	4	32.6	5.8	0.8	39.2	-	-	-	-
<b>Heath House Ln</b>	-	-	118	88	4	32.6	5.8	0.8	39.2	-	-	-	-
1/1	17	17	7	10	0	0.0	0.0	-	0.0	2.9	0.0	0.0	0.0
1/2+1/3	828	828	-	-	-	8.8	1.6	-	10.4	45.4	20.3	1.6	21.9
2/1+2/2	609	609	18	0	0	7.9	1.6	0.1	9.6	56.6	10.9	1.6	12.5
3/1	347	347	-	-	-	3.6	0.6	-	4.1	43.0	11.3	0.6	11.8
3/3+3/2	444	444	-	-	-	5.1	0.6	-	5.7	46.4	13.5	0.6	14.2
4/2+4/1	630	630	94	78	3	7.1	1.4	0.8	9.3	53.1	16.3	1.4	17.7
5/1	102	102	-	-	-	0.0	0.0	-	0.0	0.0	0.0	0.0	0.0
5/2	479	479	-	-	-	0.0	0.0	-	0.0	0.0	0.0	0.0	0.0
6/1	396	396	-	-	-	0.0	0.0	-	0.0	0.0	0.0	0.0	0.0
7/1	778	778	-	-	-	0.0	0.0	-	0.0	0.0	0.0	0.0	0.0
8/1	834	834	-	-	-	0.0	0.0	-	0.0	0.0	0.0	0.0	0.0
8/2	286	286	-	-	-	0.0	0.0	-	0.0	0.0	0.0	0.0	0.0
C1			PRC for Signalled Lanes (%):		17.9	Total Delay for Signalled Lanes (pcuHr):		39.16	Cycle Time (s): 150				
			PRC Over All Lanes (%):		17.9	Total Delay Over All Lanes(pcuHr):		39.17					

**Scenario 6: 'PM32+LP+Rich+IM'** (FG14: 'PM 2032 (All)', Plan 1: '12345')

**Stage Sequence Diagram**

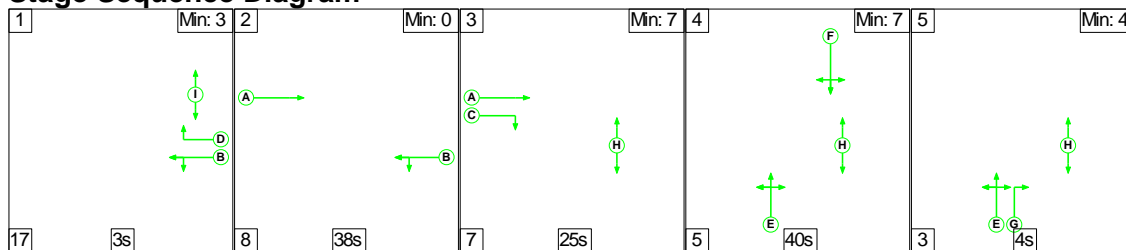

**Stage Timings**

Stage	1	2	3	4	5
Duration	3	38	25	40	4
Change Point	0	20	66	98	143

**Signal Timings Diagram**

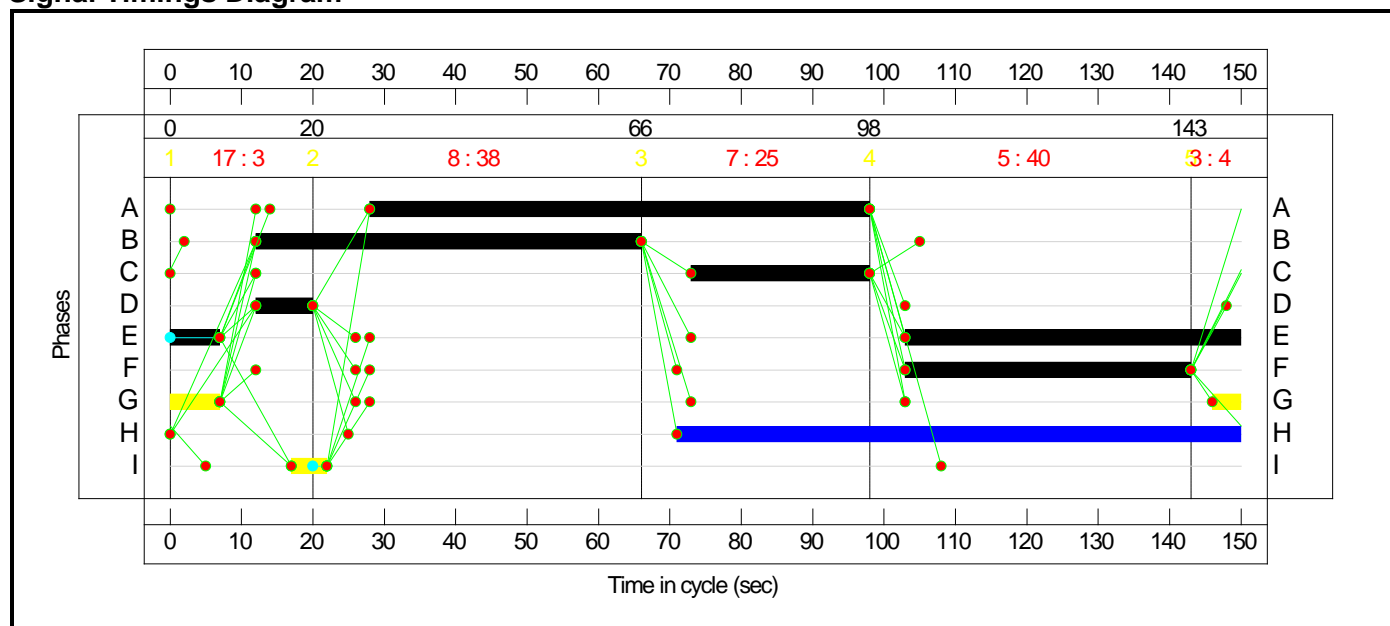

**Network Layout Diagram**

Results For Scenario: PM32+LP+Rich+IM		
Cycle Time: 150	PRC: 17.2%	Tot Delay (pcuHr): 39.76

**Heath House Ln**  
PRC: 17.2 %  
Total Traffic Delay: 39.8 pcuHr

**OPTION D**

Based on Option D from Job 16046. However, parameters updated based on latest drawing from SCC.

Intergreens re-measured according to Chapter 6 in Traffic Signs Manual

Cycle time reduced to 100s in PM, as 150s provides little extra benefit.

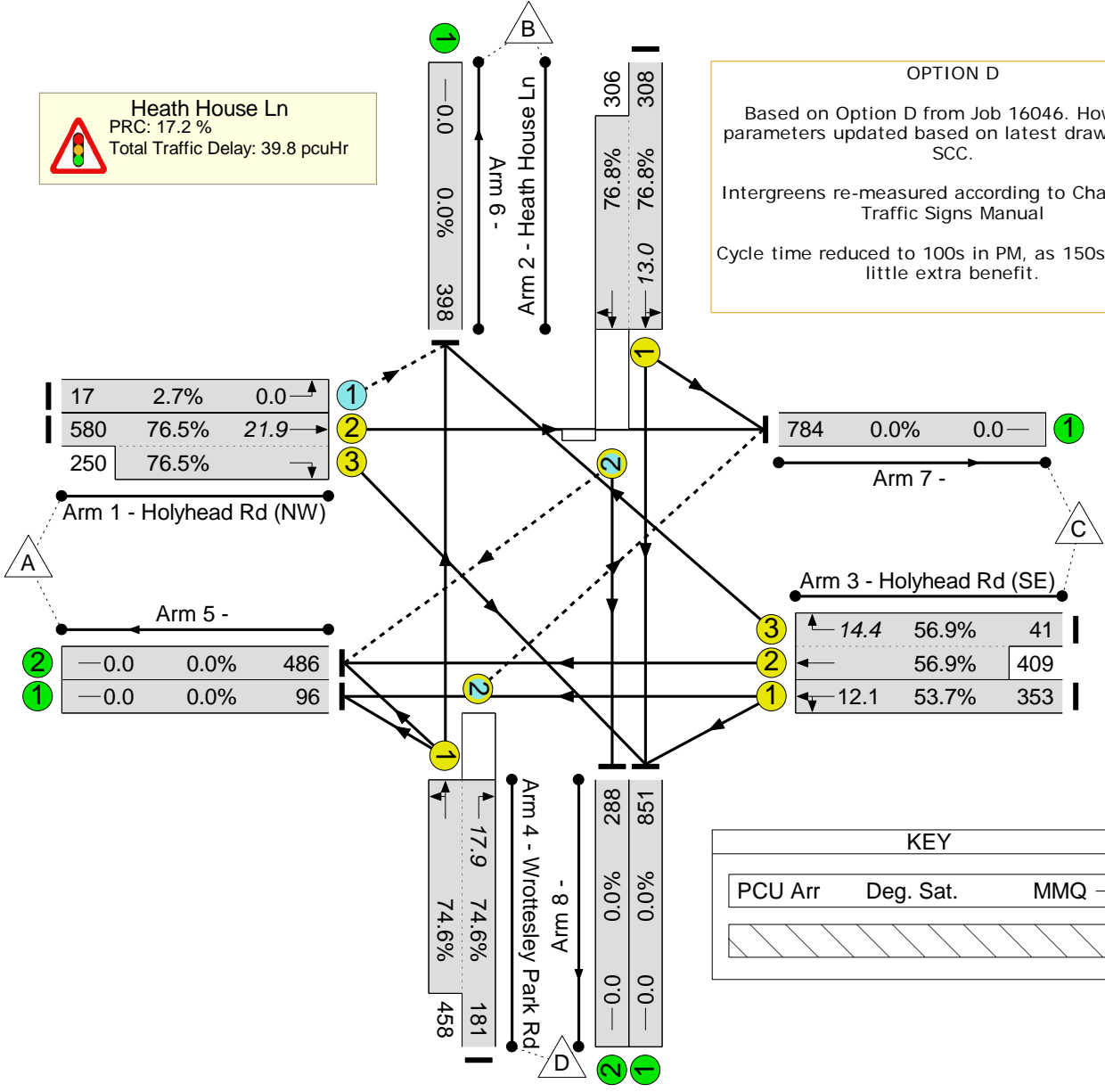

KEY		
PCU Arr	Deg. Sat.	MMQ

**Network Results**

Item	Lane Description	Lane Type	Controller Stream	Position In Filtered Route	Full Phase	Arrow Phase	Num Greens	Total Green (s)	Arrow Green (s)	Demand Flow (pcu)	Sat Flow (pcu/Hr)	Capacity (pcu)	Deg Sat (%)
<b>Network: Option D Update</b>	-	-	N/A	-	-		-	-	-	-	-	-	76.8%
<b>Heath House Ln</b>	-	-	N/A	-	-		-	-	-	-	-	-	76.8%
1/1	Holyhead Rd (NW) Left	O	N/A	N/A	-		-	-	-	17	Inf	631	2.7%
1/2+1/3	Holyhead Rd (NW) Ahead Right	U	N/A	N/A	A C		1	70:25	-	830	1965:1899	759+327	76.5 : 76.5%
2/1+2/2	Heath House Ln Right Left Ahead	U+O	N/A	N/A	F		1	40	-	614	1956:1948	401+398	76.8 : 76.8%
3/1	Holyhead Rd (SE) Ahead Left	U	N/A	N/A	B		1	54	-	353	1793	657	53.7%
3/3+3/2	Holyhead Rd (SE) Ahead Right	U	N/A	N/A	D B		1	8:54	-	450	1877:2105	72+719	56.9 : 56.9%
4/2+4/1	Wrottesley Park Rd Left Ahead Right	O+U	N/A	N/A	E	G	1	54	11	639	1665:1880	243+614	74.6 : 74.6%
5/1		U	N/A	N/A	-		-	-	-	96	Inf	Inf	0.0%
5/2		U	N/A	N/A	-		-	-	-	486	Inf	Inf	0.0%
6/1		U	N/A	N/A	-		-	-	-	398	Inf	Inf	0.0%
7/1		U	N/A	N/A	-		-	-	-	784	Inf	Inf	0.0%
8/1		U	N/A	N/A	-		-	-	-	851	Inf	Inf	0.0%
8/2		U	N/A	N/A	-		-	-	-	288	Inf	Inf	0.0%



Item	Arriving (pcu)	Leaving (pcu)	Turners In Gaps (pcu)	Turners When Unopposed (pcu)	Turners In Intergreen (pcu)	Uniform Delay (pcuHr)	Rand + Oversat Delay (pcuHr)	Storage Area Uniform Delay (pcuHr)	Total Delay (pcuHr)	Av. Delay Per PCU (s/pcu)	Max. Back of Uniform Queue (pcu)	Rand + Oversat Queue (pcu)	Mean Max Queue (pcu)
<b>Network: Option D Update</b>	-	-	116	95	4	33.0	5.9	0.8	39.8	-	-	-	-
<b>Heath House Ln</b>	-	-	116	95	4	33.0	5.9	0.8	39.8	-	-	-	-
1/1	17	17	7	10	0	0.0	0.0	-	0.0	2.9	0.0	0.0	0.0
1/2+1/3	830	830	-	-	-	8.9	1.6	-	10.5	45.4	20.3	1.6	21.9
2/1+2/2	614	614	18	0	0	8.0	1.6	0.1	9.7	56.9	11.3	1.6	13.0
3/1	353	353	-	-	-	3.7	0.6	-	4.3	43.4	11.6	0.6	12.1
3/3+3/2	450	450	-	-	-	5.2	0.7	-	5.8	46.7	13.7	0.7	14.4
4/2+4/1	639	639	92	86	4	7.3	1.4	0.8	9.5	53.4	16.4	1.4	17.9
5/1	96	96	-	-	-	0.0	0.0	-	0.0	0.0	0.0	0.0	0.0
5/2	486	486	-	-	-	0.0	0.0	-	0.0	0.0	0.0	0.0	0.0
6/1	398	398	-	-	-	0.0	0.0	-	0.0	0.0	0.0	0.0	0.0
7/1	784	784	-	-	-	0.0	0.0	-	0.0	0.0	0.0	0.0	0.0
8/1	851	851	-	-	-	0.0	0.0	-	0.0	0.0	0.0	0.0	0.0
8/2	288	288	-	-	-	0.0	0.0	-	0.0	0.0	0.0	0.0	0.0
C1			PRC for Signalled Lanes (%):		17.2	Total Delay for Signalled Lanes (pcuHr):		39.75	Cycle Time (s): 150				
			PRC Over All Lanes (%):		17.2	Total Delay Over All Lanes(pcuHr):		39.76					



---

Forester House  
Doctor's Lane  
Henley-in-Arden  
Warwickshire  
B95 5AW

Tel: +44(0)1564 793598  
[inmail@dtatransportation.co.uk](mailto:inmail@dtatransportation.co.uk)  
[www.dtatransportation.co.uk](http://www.dtatransportation.co.uk)